



# User Manual

Uninterruptible Power System

(60-500kVA)



## Preface

### Usage

The manual contains information on installing, using, operation and maintenance of the Tower UPS. Please carefully read this manual prior to installation.

### Users

Technical Support Engineer  
Maintenance Engineer

### Note

Our company is providing a full range of technical support and services. Customer can contact our local office or customer service center for help.

The manual will update irregularly, due to the product upgrading or other reasons. Unless otherwise agreed, the manual is only used as guide for users and any statements or information contained in this manual make no warranty expressed or implied.

## Contents

Preface.....	I
Contents .....	II
Safety Precautions.....	V
1 Overview.....	9
1.1 Product Description.....	9
1.2 System conceptual diagram.....	9
1.3 Power unit conceptual diagram.....	9
1.4 Working Modes .....	9
1.4.1 Normal mode.....	10
1.4.2 Battery Mode.....	10
1.4.3 Bypass Mode .....	11
1.4.4 Maintenance Mode (Manual Bypass).....	11
1.4.5 ECO Mode.....	12
1.4.6 Auto-restart Mode .....	12
1.4.7 Frequency Converter Mode.....	12
1.5 UPS Structure.....	13
1.5.1 UPS Configuration .....	13
1.5.2 UPS Structure.....	13
2 Installation.....	17
2.1 Location.....	17
2.1.1 Installation Environment .....	17
2.1.2 Site Selection.....	17
2.1.3 Weight and Dimensions.....	17
2.2 Unloading and Unpacking.....	22
2.2.1 Moving and Unpacking of the Cabinet .....	22
2.3 Positioning.....	24
2.3.1 Positioning Cabinet .....	24
2.4 Battery.....	26
2.5 Cable Entry.....	27
2.6 Power Cables.....	29
2.6.1 Specifications .....	29
2.6.2 Specifications for Power Cables Terminal .....	30
2.6.3 Circuit Breaker .....	31
2.6.4 Connecting Power Cables .....	31
2.7 Control and Communication Cables .....	33
2.7.1 Dry Contact Interface .....	34
2.7.2 Communication Interface .....	39
3 Operator Control and Display Panel .....	4

3.1	UPS operator panel .....	40
3.1.1	LED Indicator .....	40
3.1.2	Control and Operation Keys .....	41
3.1.3	LCD touch Screen .....	42
3.2	Main Menu .....	43
3.2.1	Cabinet .....	43
3.2.2	Power unit .....	45
3.2.3	Setting .....	47
3.2.4	Log .....	49
3.2.5	Operate .....	56
3.2.6	Scope .....	58
4	Operations .....	59
4.1	UPS Start-up .....	59
4.1.1	Start in Normal Mode .....	59
4.1.2	Start from Battery .....	60
4.2	Procedure for Switching between Operation Modes .....	60
4.2.1	Switching the UPS into Battery Mode from Normal Mode .....	60
4.2.2	Switching the UPS from Normal Mode into Bypass Mode .....	60
4.2.3	Switching the UPS into Normal Mode from Bypass Mode .....	61
4.2.4	Switching the UPS from Normal Mode into Maintenance Bypass Mode .....	61
4.2.5	Switching the UPS into Normal Mode from Maintenance Bypass Mode .....	62
4.3	Battery Manual .....	62
4.4	EPO .....	64
4.5	Installation of Parallel Operation System .....	65
5	Maintenance .....	67
5.1	Precautions .....	67
5.2	Instruction for Maintaining Power unit .....	67
5.3	Instruction for Maintaining monitor unit and bypass unit .....	67
5.3.1	Maintaining monitor unit and bypass unit for 60kVA-120kVA .....	67
5.3.2	Maintaining monitor unit and bypass unit for 150kVA and 300kVA .....	68
5.3.3	Maintaining monitor unit and bypass unit for 400kVA and 500kVA .....	68
5.4	Battery Setting .....	68
5.4.1	Setting of Battery Type .....	69
5.4.2	Setting of Battery Number .....	69
5.4.3	Battery Capacity Setting .....	70
5.4.4	Float and Boost Charge Setting .....	70
5.4.5	EOD Voltage Setting .....	70
5.4.6	Charging Current Percent Limit .....	70
5.4.7	Battery Temperature Compensate .....	71

---

5.4.8	Boost Charge Time Limit .....	71
5.4.9	Auto Boost Period .....	71
5.4.10	Auto maintenance Discharge Period .....	71
5.4.11	Warnings for Battery and Environment Temperature Overheat .....	72
5.5	Replacing Dust Filter (optional).....	72
6	Product Specification .....	73
6.1	Applicable Standards.....	73
6.2	Environmental Characteristics .....	73
6.3	Mechanical Characteristic .....	74
6.4	Electrical Characteristics.....	74
6.4.1	Electrical Characteristics (Input Rectifier).....	74
6.4.2	Electrical Characteristics (Intermediate DC Link) .....	75
6.4.3	Electrical Characteristics (Inverter Output).....	75
6.4.4	Electrical Characteristics (Bypass Mains Input) .....	76
6.5	Efficiency .....	76
6.6	Display and Interface .....	76

## Safety Precautions

This manual contains information concerning the installation and operation of Tower UPS. Please carefully read this manual prior to installation.

The Tower UPS cannot be put into operation until it is commissioned by engineers approved by the manufacturer (or its agent). Not doing so could result in personnel safety risk, equipment malfunction and invalidation of warranty.

### Safety Message Definition

**Danger:** Serious human injury or even death may be caused, if this requirement is ignored.



**Warning:** Human injury or equipment damage may be caused, if this requirement is ignored.

**Attention:** Equipment damage, loss of data or poor performance may be caused, if this requirement is ignored.





**Commissioning Engineer:** The engineer who installs or operates the equipment should be well trained in electricity and safety and familiar with the operation, debug, and maintenance of the equipment.

### Warning Label



The warning label indicates the possibility of human injury or equipment damage, and advises the proper step to avoid the danger. In this manual, there are three types of warning labels as below.

Labels	Description
 <b>Danger</b>	Serious human injury or even death may be caused, if this requirement is ignored.
 <b>Warning</b>	Human injury or equipment damage may be caused, if this requirement is ignored.
 <b>Attention</b>	Equipment damage, loss of data or poor performance may be caused, if this requirement is ignored.



### Safety Instruction

 <b>Danger</b>	Performed only by commissioning engineers. This UPS is designed for commercial and industrial applications only, and is not intended for any use in life-support devices or system.
 <b>Warning</b>	Read all the warning labels carefully before operation, and follow the instructions.
	When the system is running, do not touch the surface with this label, to avoid any hurt of scald.
	ESD sensitive components inside the UPS, anti-ESD measure should be taken before handling.

### Move & Install

 <b>Danger</b>	<p>Keep the equipment away from heat source or air outlets. In case of fire, use dry powder extinguisher only, any liquid extinguisher can result in electric shock.</p>
 <b>Warning</b>	<p>Do not start the system if any damage or abnormal parts founded. Contacting the UPS with wet material or hands may be subject to electric shock.</p>
 <b>Attention</b>	<p>Use proper facilities to handle and install the UPS. Shielding shoes, protective clothes and other protective facilities are necessary to avoid injury. During positioning, keep the UPS way from shock or vibration. Install the UPS in proper environment, more detail in section 3.3.</p>

### Debug & Operate

 <b>Danger</b>	<p>Make sure the grounding cable is well connected before connecting the power cables, the grounding cable and neutral cable must be in accordance with the local and national codes practice. Before moving or re-connecting the cables, make sure to cut off all the input power sources, and wait for at least 10 minutes for internal discharge. Use a multi-meter to measure the voltage on terminals and ensure the voltage is lower than 36V before operation. <b>Risk of Voltage Backfeed. Before working on the circuits, isolate the Uninterruptible Power Supply (UPS), and then check for Hazardous Voltage between all terminals including the protective earth.</b></p>
 <b>Attention</b>	<p>The earth leakage current of load will be carried by RCCB or RCD. Initial check and inspection should be performed after long time storing of UPS.</p>

### Maintenance & Replacement

 <b>Danger</b>	<p>All the equipment maintenance and servicing procedures involving internal access need special tools and should be carried out only by trained personnel. The components that can only be accessed by opening the protective cover with tools cannot be maintained by user. This UPS full complies with “IEC62040-1-1-General and safety requirements for use in operator access area UPS”. Dangerous voltages are present within the battery box. However, the risk of contact with these high voltages is minimized for non-service personnel. Since the component with dangerous voltage can only be touched by opening the protective cover with a tool, the possibility of touching high</p>
---	---

voltage component is minimized. No risk exists to any personnel when operating the equipment in the normal manner, following the recommended operating procedures in this manual.

**Risk of Fire. TO REDUCE THE RISK OF RIFE, REPLACE FUSES WITH THE SAME TYPE AND RATINGS. DISCONNECT OUTPUT AND ALL INPUT SOURCES OF POWER FROM THIS EQUIPMENT BEFORE SERVICING.**

**Battery Safety**



**Danger**

All the battery maintenance and servicing procedures involving internal access need special tools or keys and should be carried out only by trained personnel.

**WHEN CONNECTED TOGETHER, THE BATTERY TERMINAL VOLTAGE WILL EXCEED 400Vdc AND IS POTENTIALLY LEATHAL.**

Battery manufacturers supply details of the necessary precautions to be observed when working on, or in the vicinity of, a large bank of battery cells. These precautions should be followed implicitly at all times. Particular attention should be paid to the recommendations concerning local environmental conditions and the provision of protective clothing, first aid and fire-Figure ting facilities.

Ambient temperature is a major factor in determining the battery capacity and life. The nominal operating temperature of battery is 20°C. Operating above this temperature will reduce the battery life. Periodically change the battery according to the battery user manuals to ensure the back-up time of UPS.

Replace the batteries only with the same type and the same number, or it may cause explosion or poor performance. When connecting the battery, follow the precautions for high-voltage operation before accepting and using the battery, check the appearance the battery. If the package is damaged, or the battery terminal is dirty, corroded or rusted or the shell is broken, deformed or has leakage, replace it with new product. Otherwise, battery capacity reduction, electric leakage or fire may be caused.

Before operating the battery, remove the finger ring, watch, necklace, bracelet and any other metal jewelry  
Wear rubber gloves.

Eye protection should be worn to prevent injury from accidental electrical arcs.

Only use tools (e.g. wrench) with insulated handles.

The batteries are very heavy. Please handle and lift the battery with proper method to prevent any human injury or damage to the battery terminal.

Do not decompose, modify or damage the battery. Otherwise, battery short circuit, leakage or even human injury may be caused.

	<p>The battery contains sulfuric acid. In normal operation, all the sulfuric acid is attached to the separation board and plate in the battery. However, when the battery case is broken, the acid will leak from the battery. Therefore, be sure to wear a pair of protective glasses, rubber gloves and skirt when operating the battery. Otherwise, you may become blind if acid enters your eyes and your skin may be damaged by the acid.</p> <p>At the end of battery life, the battery may have internal short circuit, drain of electrolytic and erosion of positive/negative plates. If this condition continues, the battery may have temperature out of control, swell or leak. Be sure to replace the battery before these phenomena happen.</p> <p>If a battery leaks electrolyte, or is otherwise physically damaged, it must be replaced, stored in a container resistant to sulfuric acid and disposed of in accordance with local regulations.</p> <p>If electrolyte comes into contact with the skin, the affected area should be washed immediately with water.</p>
--	--

**Disposal**

	<p><b>Warning</b></p> <p>Dispose of used battery according to the local instructions</p>
--	--

# 1 Overview

## 1.1 Product Description

This series Tower UPS is an online double-conversion UPS that uses digital signal processing(DSP) technology. Provide a stable and uninterrupted power supply for the important load.

## 1.2 System conceptual diagram

The Tower UPS is configured by the following part: Power modules, Bypass & Monitoring module, and cabinet with manual Bypass switch. One or several battery strings should be installed to provide backup energy once the utility fails. The UPS structure is shown in Figure 1-1.

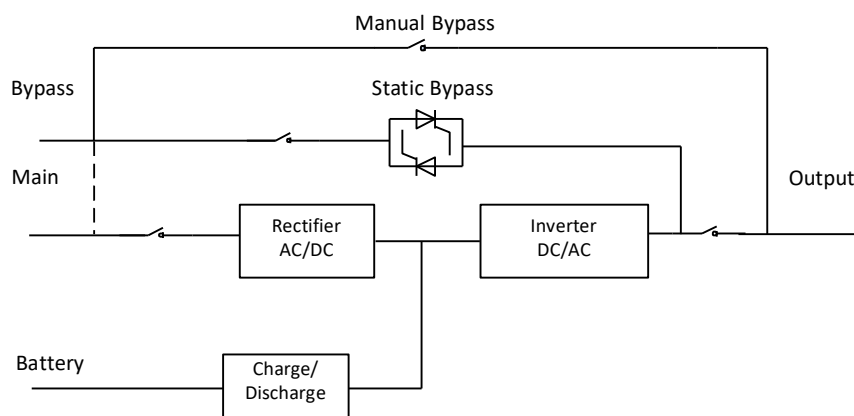

Figure 1-1 UPS Conceptual Diagram

## 1.3 Power unit conceptual diagram

The power unit conceptual diagram is shown as Figure 1-2. The Power unit contains a rectifier, an inverter, and a DC/DC converter for charge and discharge of the external batteries.

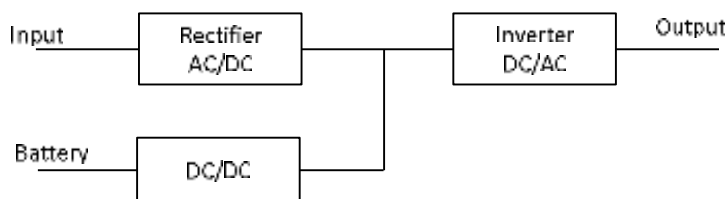

Figure1-2 Power unit conceptual diagram

## 1.4 Working Modes

The Modular UPS is an on-line, double-conversion UPS that permits operation in the following modes:

- Normal mode
- Battery mode
- Bypass mode
- Maintenance mode (manual bypass)
- ECO mode
- Auto-restart mode
- Frequency Converter mode

### 1.4.1 Normal mode

The inverter of power modules continuously supply the critical AC load. The rectifier/charger derives power from the AC mains input source and supplies DC power to the inverter while simultaneously FLOAT or BOOST charging its associated backup battery.

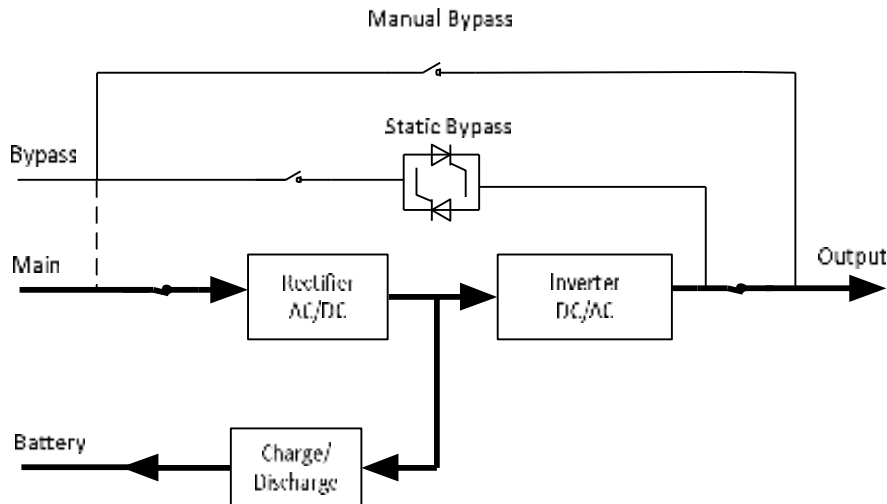

Figure1-3 UPS conceptual diagram in normal mode



➔ Indicates the energy flow direction.

### 1.4.2 Battery Mode

Upon failure of the AC mains input power, the inverter of power unit, which obtain power from the battery, supply the critical AC load. There is no interruption in power to the critical load upon failure. After restoration of the AC mains input power, the "Normal mode" operation will continue automatically without the necessity of user intervention.

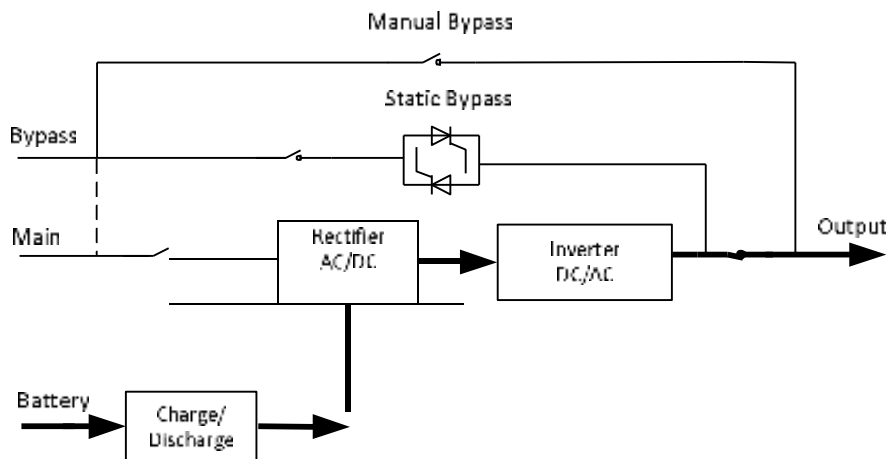

Figure1-4 UPS conceptual diagram in Battery mode



With the function of Battery cold start, the UPS may start without utility. See more detail in section 4.1.2.

### 1.4.3 Bypass Mode

If the inverter overload capacity is exceeded under Normal mode, or if the inverter becomes unavailable for any reason, the static transfer switch will perform a transfer of the load from the inverter to the bypass source, with no interruption in power to the critical AC load. Should the inverter be asynchronous with the bypass, the static switch will perform a transfer of the load from the inverter to the bypass with power interruption to the load. This is to avoid large cross currents due to the paralleling of unsynchronized AC sources. This interruption is programmable but typically set to be less than 3/4 of an electrical cycle, e.g., less than 15ms (50Hz) or less than 12.5ms (60Hz). The action of transfer/re-transfer can also be done by the command through monitor.

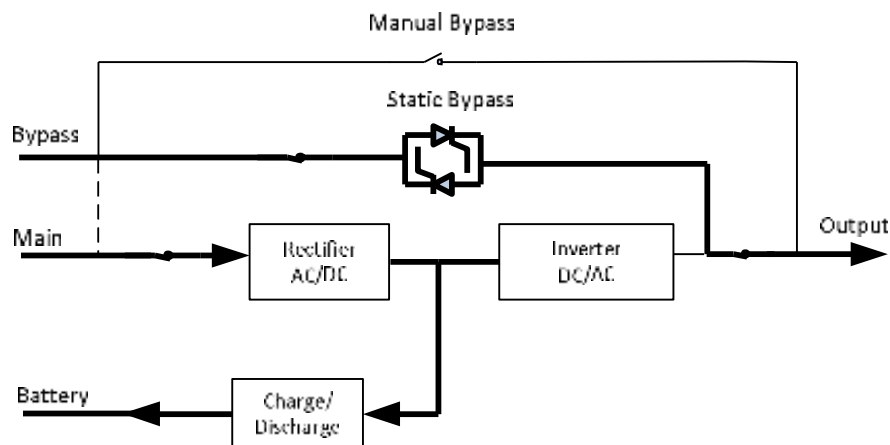

Figure1-5 UPS conceptual diagram in Bypass Mode

### 1.4.4 Maintenance Mode (Manual Bypass)

A manual bypass switch is available to ensure continuity of supply to the critical load when the UPS becomes unavailable e.g. during a maintenance procedure.

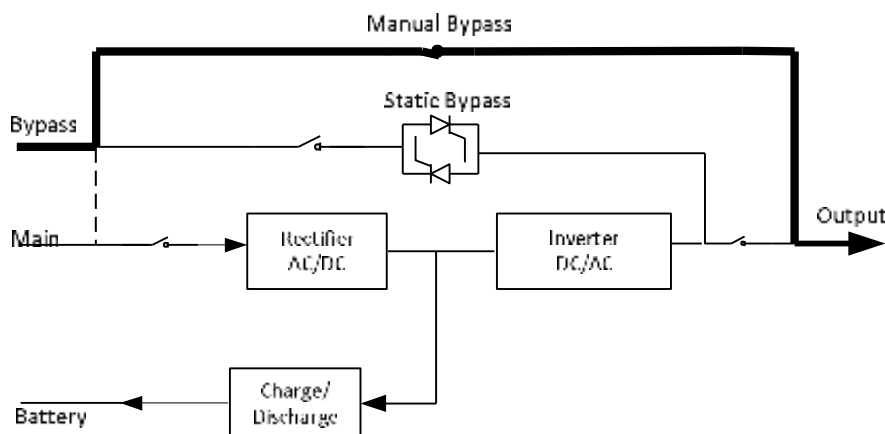

Figure1-6 UPS conceptual diagram in Maintenance Mode



### Danger

During Maintenance mode, dangerous voltages are present on the terminal of input, output and neutral, even with all the modules and the LCD turned off.

The UPS which without External maintenance switch in Maintenance Mode, dangerous voltages are present on terminal and internal Copper bar.

## 1.4.5 ECO Mode

The economy control operation (ECO) mode is an energy-saving mode, In ECO mode, when the bypass input voltage is within the ECO voltage range, the static bypass turns on, and the bypass supplies power, and inverter is standby. When the bypass input voltage is beyond the ECO voltage range, the UPS transfers from bypass mode to normal mode.

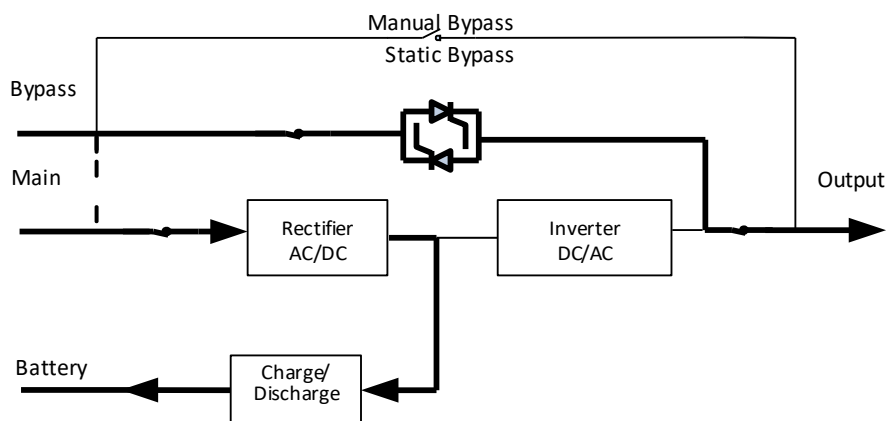

Figure1-7 UPS conceptual diagram in ECO Mode



### Note

There is a short interruption time (less than 10ms) when transfer from ECO mode to battery mode, it must be sure that the interruption has no effect on loads.

## 1.4.6 Auto-restart Mode

The battery may become exhausted following an extended AC mains failure. The inverter shuts down when the battery reaches the End of Discharge Voltage (EOD). The UPS may be programmed to “System Auto-Start Mode after EOD”. The system starts after a delay time when the AC main recovers. The mode and the delay time are programmed by the commissioning engineer.

## 1.4.7 Frequency Converter Mode

By setting the UPS to Frequency Converter mode, the UPS could present a stable output of fixed frequency (50 or 60Hz), and the bypass static switch is not available.

## 1.5 UPS Structure

### 1.5.1 UPS Configuration

The UPS configuration is provided in Table 1-1.

Table 1-1 UPS Configuration

Item	Components	Quantity/ pcs	Remark
60kVA 80kVA 90kVA 100kVA 120kVA 400kVA 500kVA	Circuit Breaker	4	factory installed
	Bypass & Monitoring unit	1	factory installed
150kVA 200kVA	Manual Bypass Breaker	1	factory installed
250kVA 300kVA	Bypass & Monitoring unit	1	factory installed
30kVA Power unit	Power unit	1~4	Except for 400kVA and 500kVA, all of the factory configuration
50kVA Power unit	Power unit	1~10	Except for 400kVA and 500kVA, all of the factory configuration



Note  
60kVA, 90kVA, 120kVA configuration 30kVA power unit, the other UPS configuration 50kVA power unit.

### 1.5.2 UPS Structure

The UPS structure is shown in Figure 1-8.

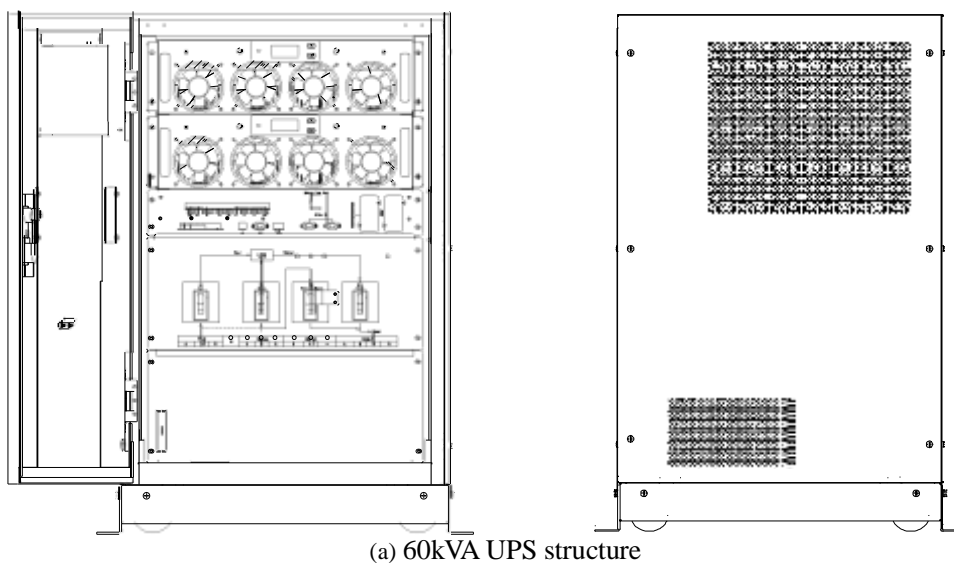

(a) 60kVA UPS structure

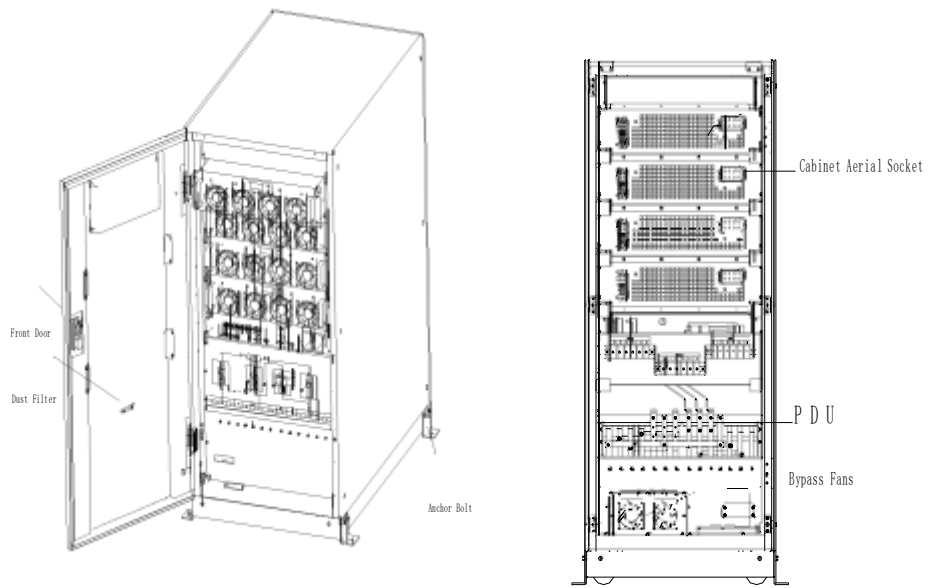

(b) 90kVA and 120kVA UPS structure

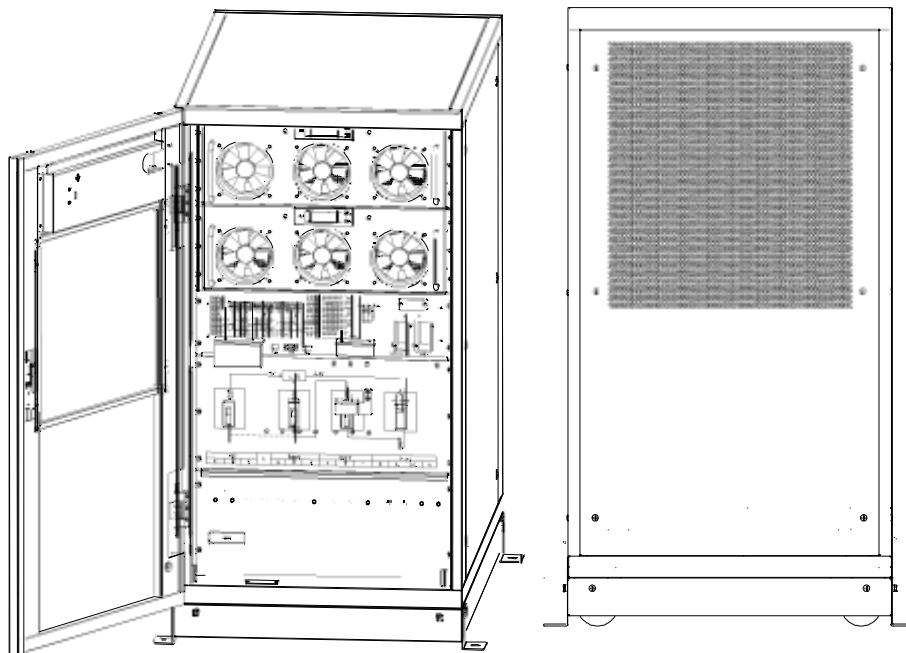

(c) 80kVA and 100kVA UPS structure

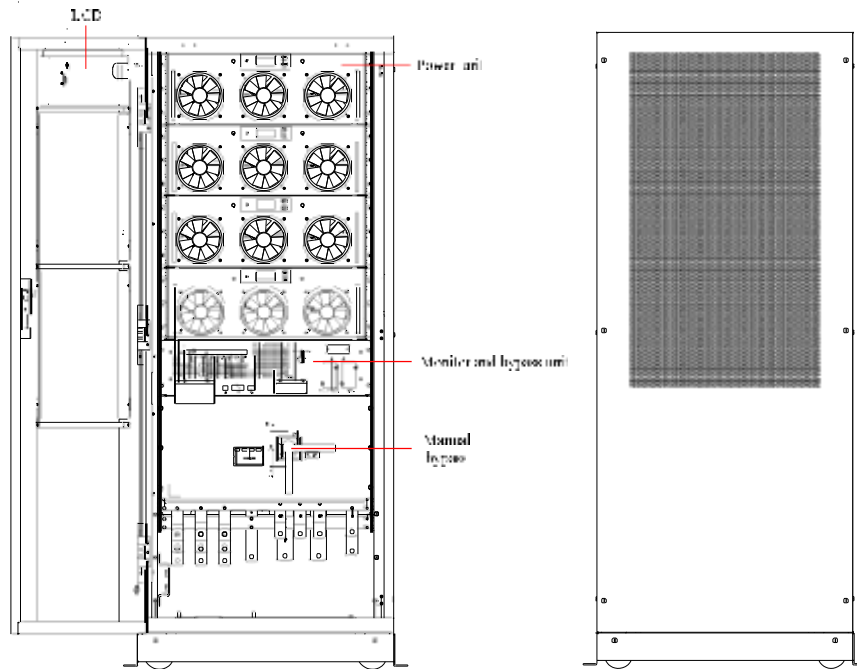

(d) 150kVA and 200kVA UPS structure

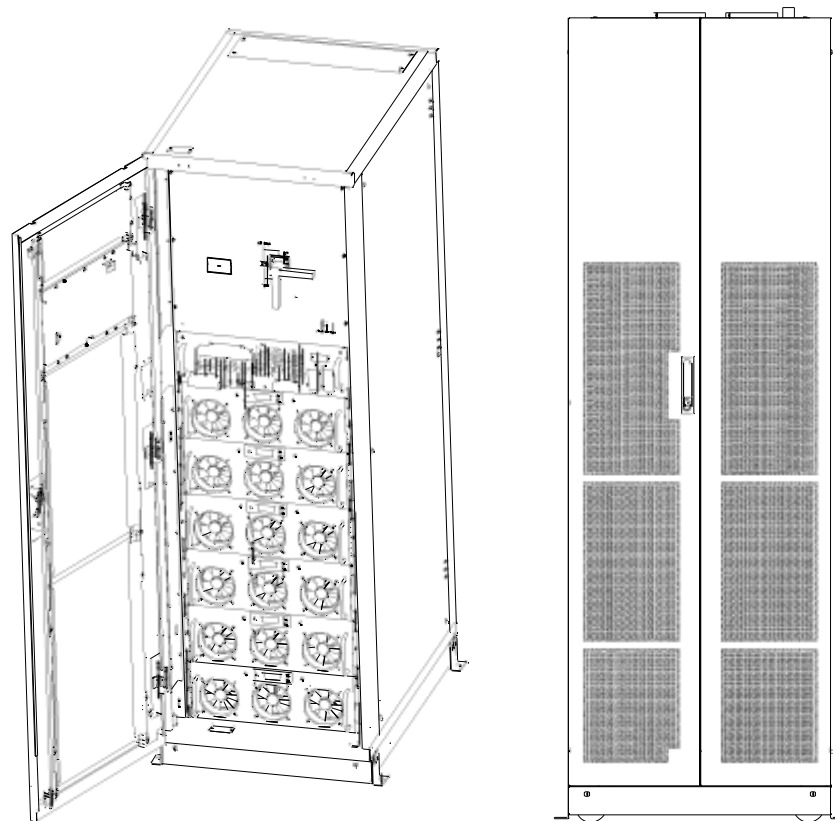

(e) 250kVA and 300kVA UPS structure

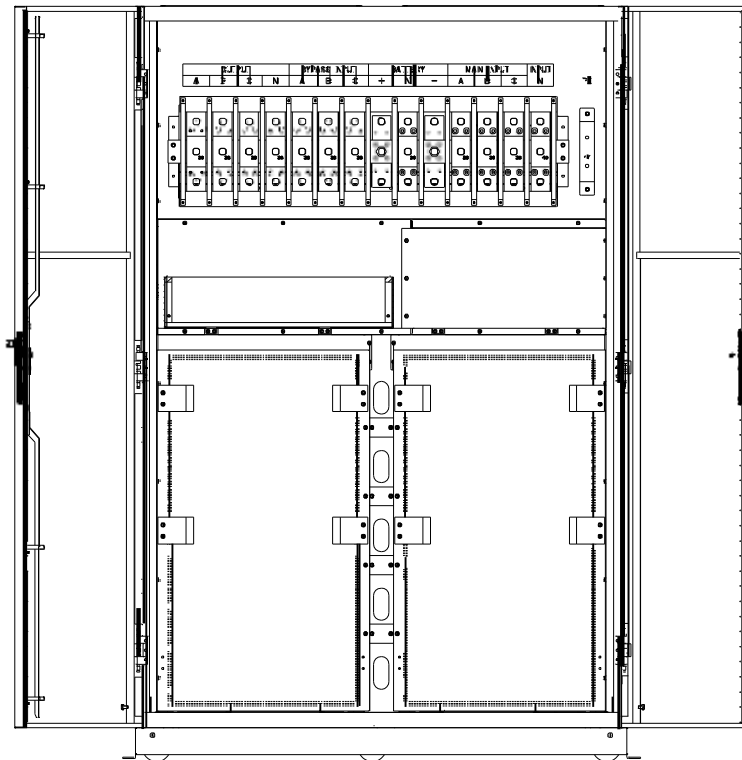
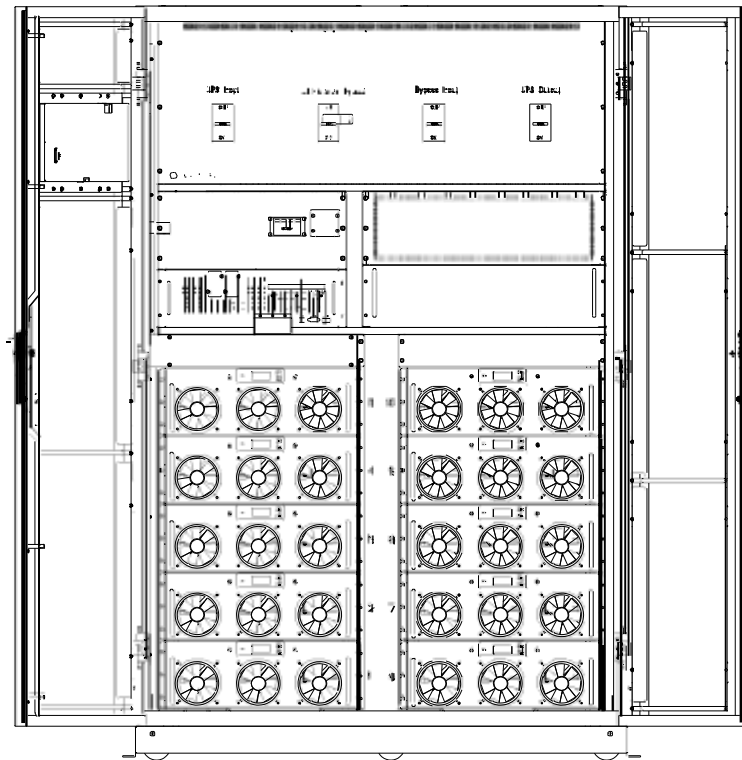

(f) 400kVA and 500kVA UPS structure

Figure1-8 UPS structure

## 2 Installation

### 2.1 Location

As each site has its requirements, the installation instructions in this section are to act as a guide for the general procedures and practices that should be observed by the installing engineer.

#### 2.1.1 Installation Environment

The UPS is intended for indoor installation and uses forced convection cooling by internal fans. Please make sure there is enough space for the UPS ventilation and cooling.

Keep the UPS far away from water, heat and inflammable and explosive, corrosive material. Avoid installing the UPS in the environment with direct sunlight, dust, volatile gases, corrosive material and high salinity.

Avoid installing the UPS in the environment with conductive dirt.

The operating environment temperature for battery is 20°C-25°C. Operating above 25°C will reduce the battery life, and operation below 20°C will reduce the battery capacity.

The battery will generate a little amount of hydrogen and oxygen at the end of charging; ensure the fresh air volume of the battery installation environment must meet EN50272-2001 requirements.

If external batteries are to be used, the battery circuit breakers (or fuses) must be mounted as close as possible to the batteries, and the connecting cables should be as short as possible.

#### 2.1.2 Site Selection

Ensure the ground or installation platform can bear the weight of the UPS cabinet, batteries and battery rack.



Attention

The UPS cabinet, battery can battery rack are suitable for mounting on concrete or other non-combustible surface on

No vibration and less than 5 degree inclination horizontally.

The equipment should be stored in a room so as to protect it against excessive humidity and heat sources.

The battery needs to be stored in dry and cool place with good ventilation. The most suitable storage temperature is 20 °C to 25°C.

#### 2.1.3 Weight and Dimensions

The size of three views for the UPS cabinet is shown in Figure 2-2.



Attention

Ensure there is at least 0.8m before the front of the cabinet so as to easily maintain the power module with the front door fully open and at least 0.5m behind for ventilation and cooling. The room reserved for the cabinet is shown in Figure 2-1.

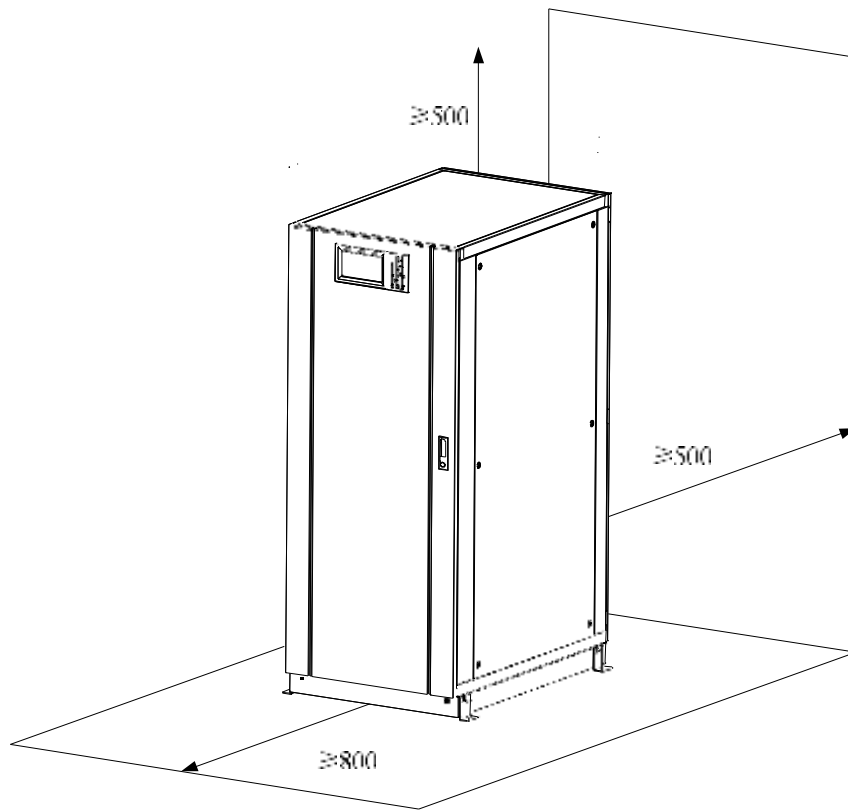
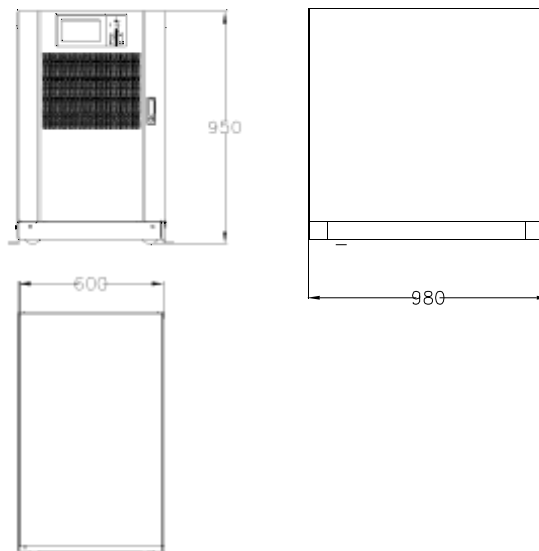
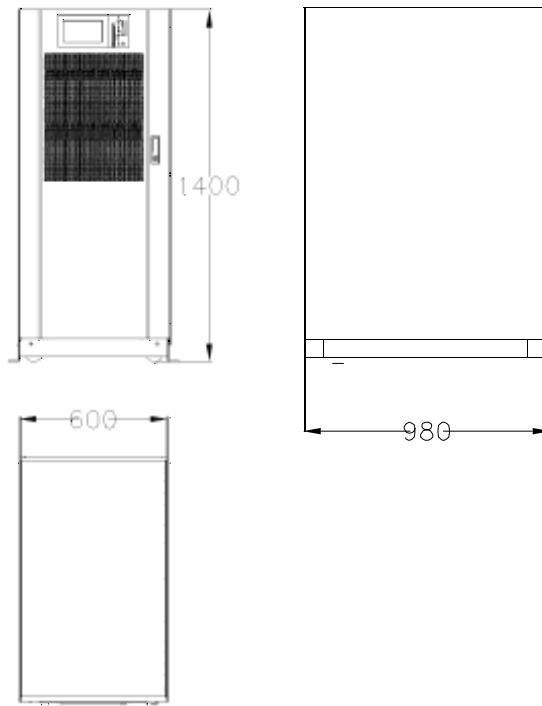

Figure2-1 Room reserved for the cabinet (Unit: mm)



(a) Dimensions of 60KVA (unit: mm)



(b) Dimensions of 90KVA and 120kVA (unit: mm)

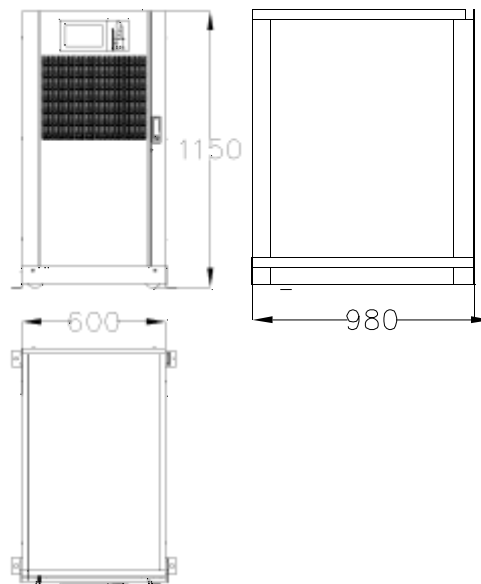

(c) Dimensions of 80KVA and 100kVA (unit: mm)

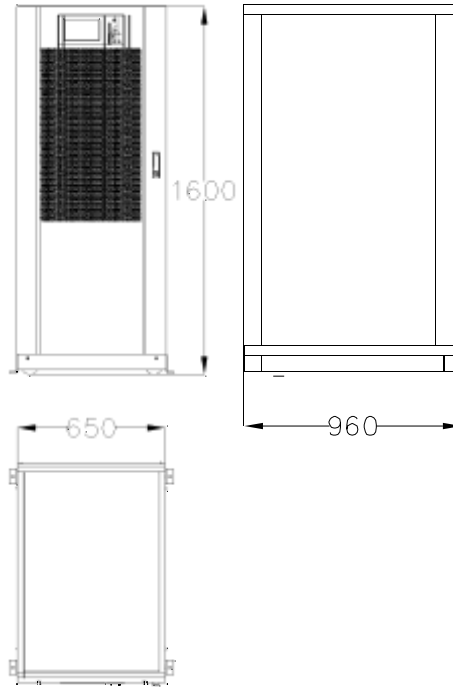

(d) Dimensions of 150KVA and 200kVA (unit: mm)

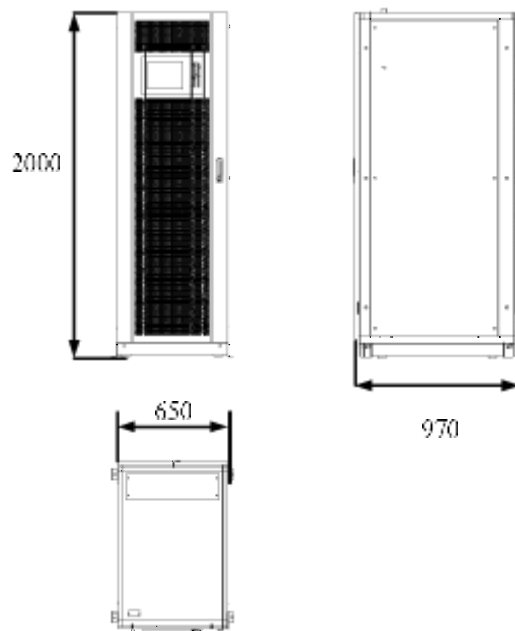

(e) Dimensions of 250kVA and 300kVA (unit: mm)

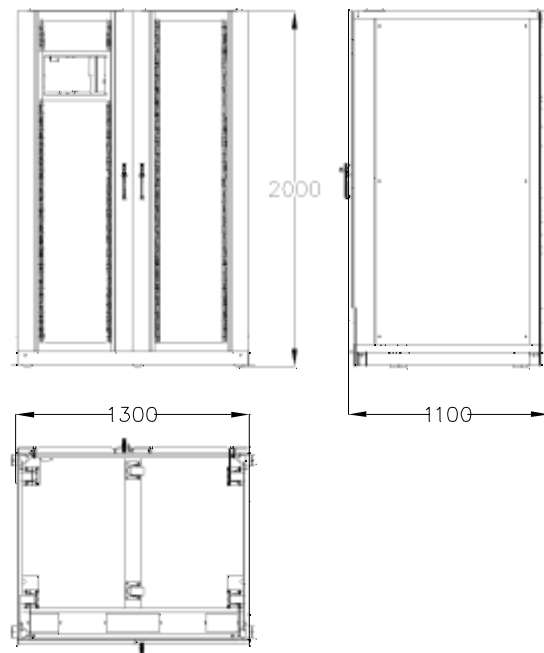

(f) Dimensions of 400KVA and 500kVA (unit: mm)

Figure2-2 Dimensions

Ensure that the floor or installation support can bear the weight of the UPS, batteries, and battery racks. The weight of batteries and battery racks depends on the site requirements. The weight for the UPS cabinet is shown in Table 2-1.

Table 2-1 weight for the UPS

Capacity	Weight
60KVA	170Kg
80KVA	210Kg
90KVA	231Kg
100KVA	210Kg
120KVA	266Kg
150KVA	305 Kg
200KVA	350 Kg
250KVA	445 Kg
300KVA	490 Kg
400KVA	810 Kg
500KVA	900 Kg

## 2.2 Unloading and Unpacking

### 2.2.1 Moving and Unpacking of the Cabinet

The steps to move and unpack the cabinet are as follows:

- 1) Check if any damages to the packing. (If any, contact to the carrier)
- 2) Transport the equipment to the designated site by forklift, as shown in Figure2-3.

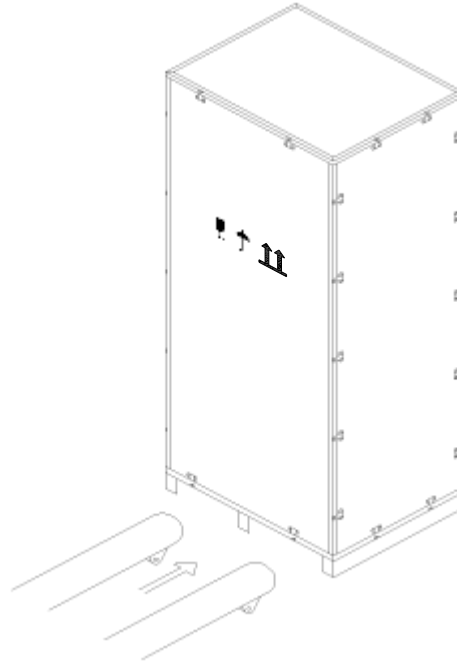

Figure2-3 Transport to the designated site

- 3) Open the top plate of the steel-edged wooden case with slotted awl and pier, followed by sideboards (see Figure2-4).

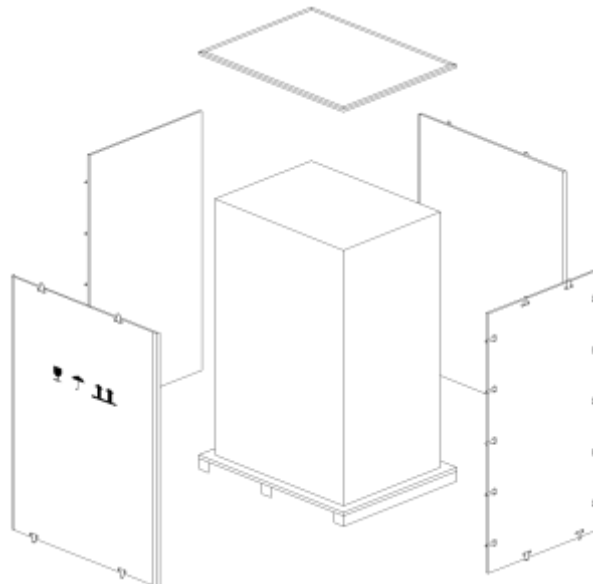

Figure2-4 Disassemble the case

- 4) Remove the protective foam around the cabinet.

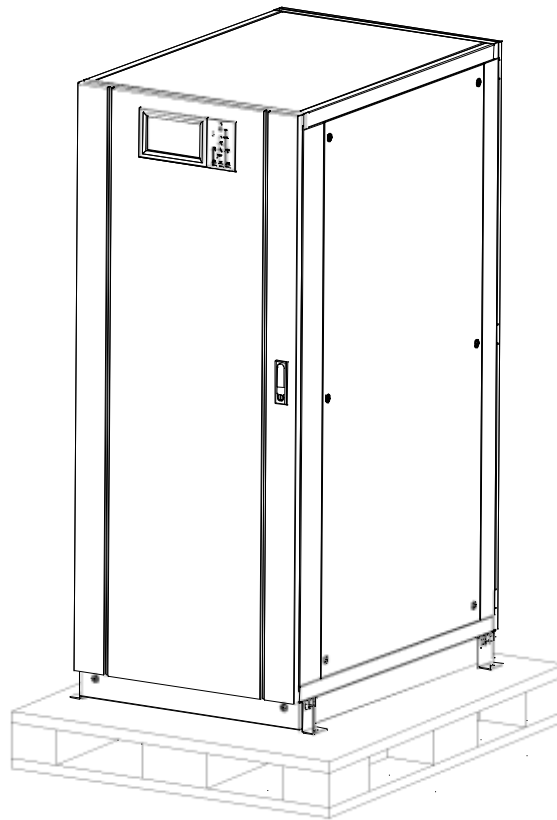

Figure2-5 Remove the protective foam

- 5) Check the UPS.
  - (a) Visually examine if there are any damages to UPS during transportation. If any, contact to the carrier.
  - (b) Check the UPS with the list of the goods. If any items are not included in the list, contact to our company or the local office.
- 6) Dismantle the bolt that connects the cabinet and wooden pallet after disassembly.
- 7) Move the cabinet to the installation position.



**Attention**

Be careful while removing to avoid scratching the equipment.

---



**Attention**

The waste materials of unpacking should be disposed to meet the demand for environmental protection.

---

## 2.3 Positioning

### 2.3.1 Positioning Cabinet

The UPS cabinet has two way of supporting itself: One is to support itself temporarily by the four wheels at the bottom, making it convenient to adjust the position of the cabinet; The other is by anchor bolts to support the cabinet permanently after adjusting the position of the cabinet. The supporting structure is shown in Figure 2-6.

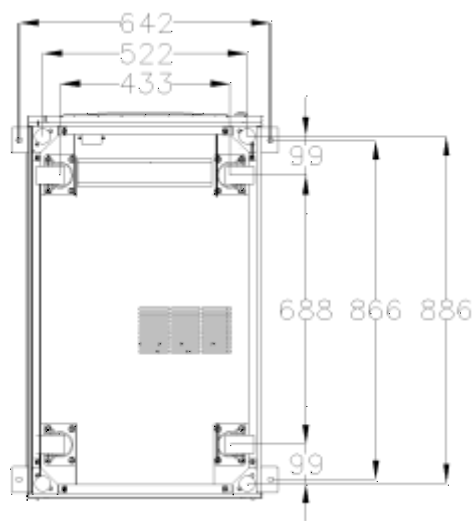

(a) Supporting structure of 60kVA, 90kVA and 120kVA (Bottom view, unit: mm)

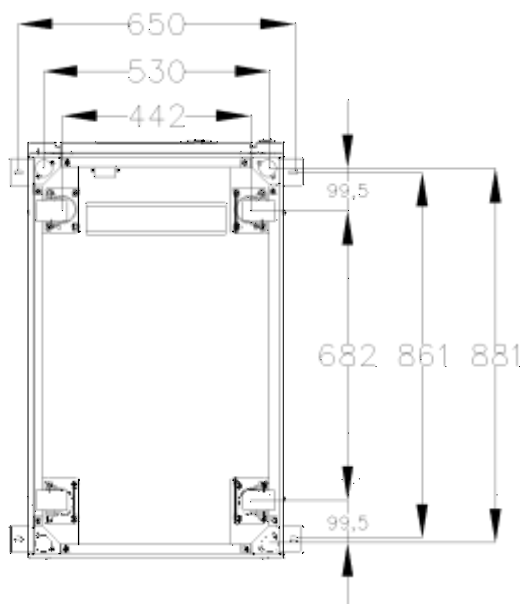

(b) Supporting structure of 80kVA and 100kVA (Bottom view, unit: mm)

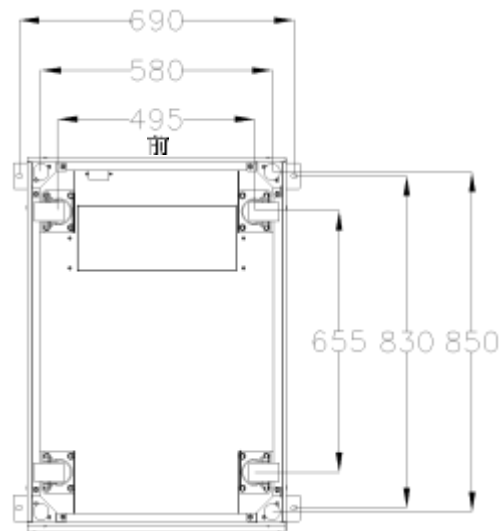

(c) Supporting structure of 150kVA, 200kVA, 250kVA and 300kVA (Bottom view, unit: mm)

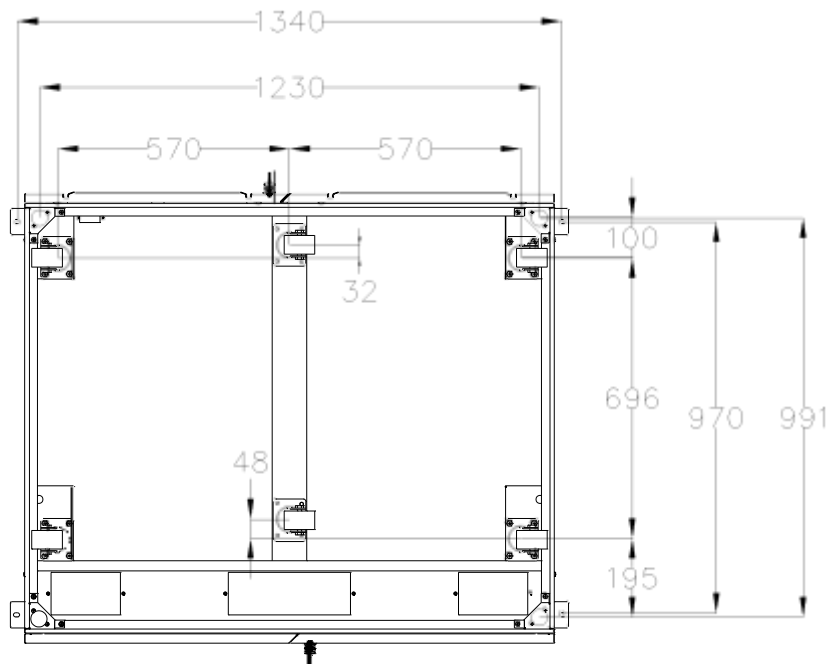

(d) Supporting structure of 400kVA and 500kVA (Bottom view, unit: mm)

Figure2-6 Supporting structure

The steps to position the cabinet are as follows:

- 1) Ensure the supporting structure is in good condition and the mounting floor is smooth and strong.
- 2) Retract the anchor bolts by turning them counter clock wise using wrench. The cabinet is then supported by the four wheels.
- 3) Adjust the cabinet to the right position by the supporting wheels.
- 4) Put down the anchor bolts by turning them clock wise using wrench, the cabinet is then supported by the four anchor bolts.
- 5) Ensure the four anchor bolts are in the same height and the cabinet is fixed and immovable.
- 6) Positioning done.



### Attention

Auxiliary equipment is needed when the mounting floor is not solid enough to support the cabinet, which helps distribute the weight over a larger area. For instance, cover the floor with iron plate or increase the supporting area of the anchor bolts.

## 2.4 Battery

Three terminals (positive, neutral, negative) are drawn from the battery unit and connected to UPS system. The neutral line is drawn from the middle of the batteries in series (See Figure2-7).

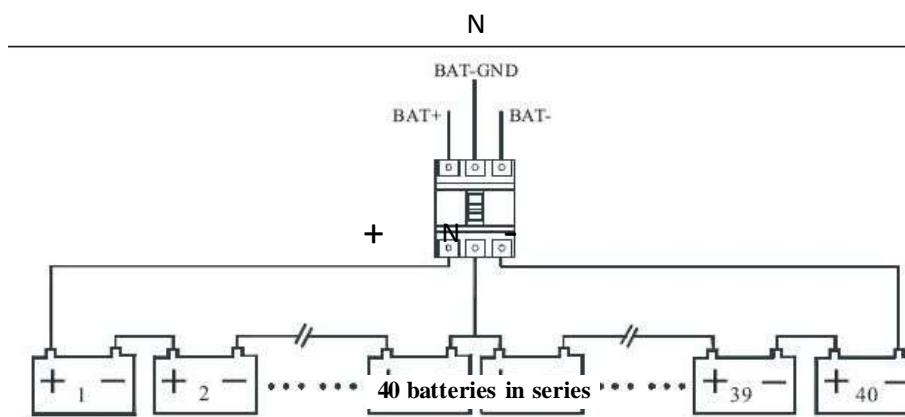

Figure2-7Batterystringwiringdiagram



### Danger

The battery terminal voltage is of more than 200Vdc, please follow the safety instructions to avoid electric shock hazard.

Ensure the positive, negative, neutral electrode is correctly connected from the battery unit terminals to the breaker and from the breaker to the UPS system.

## 2.5 Cable Entry

Cables can enter the 60kVA-200kVA cabinet from the bottom, can enter the 250kVA-300kVA cabinet from the top, and can enter the 400kVA-500kVA cabinet both from the top and bottom. The cable entry is shown in Figure2-8.

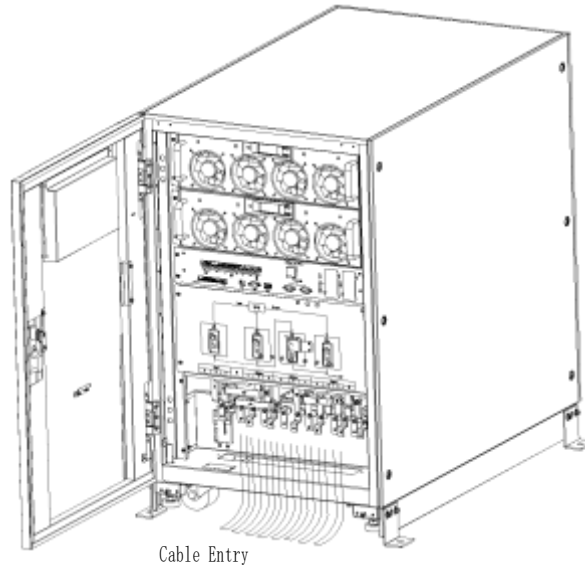

Cable Entry

(a) Cable Entry of 60kVA-200kVA

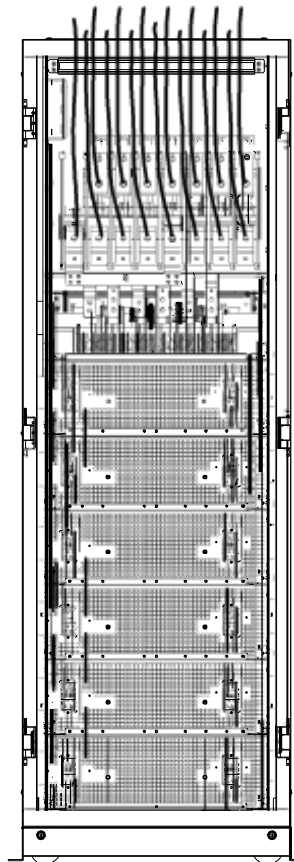

(b) Cable Entry of 250kVA-300kVA

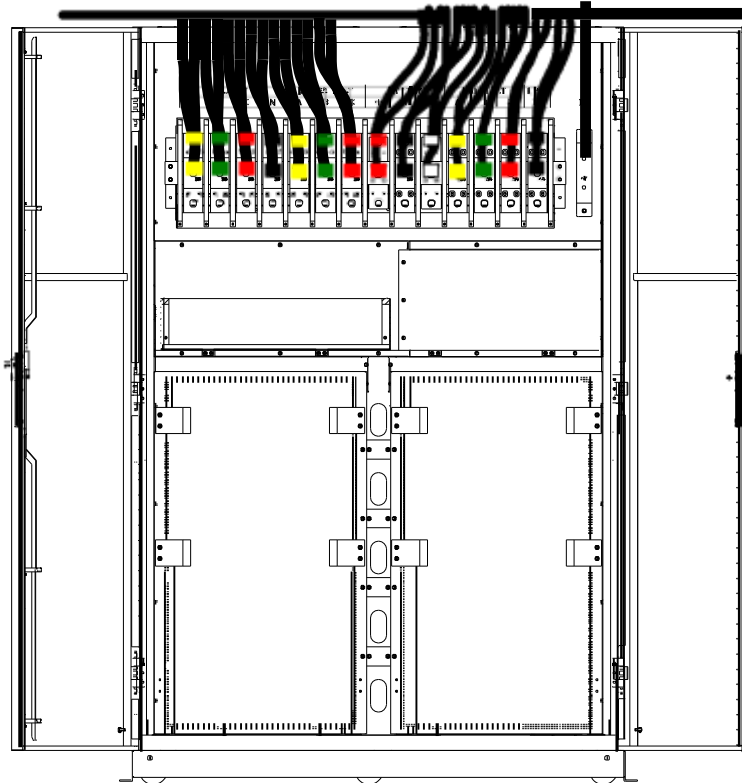

(c) Top cable Entry of 400kVA and 500kVA

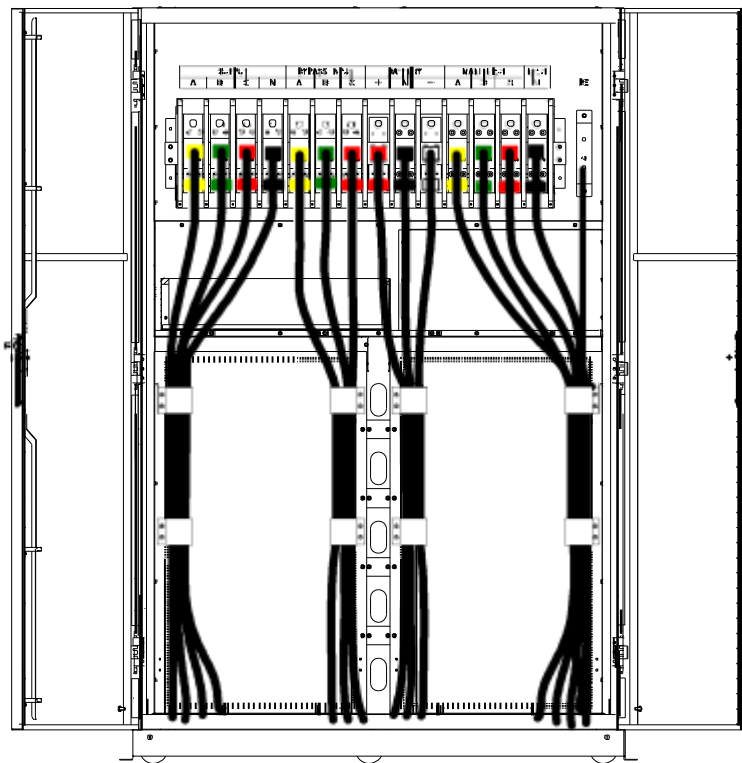

(d) Bottom cable Entry of 400kVA and 500kVA

Figure2-8 Cable Entry

## 2.6 Power Cables

### 2.6.1 Specifications

The UPS power cables are recommended in Table 2-2.

Table 2-2 Recommended cables for power cables

Contents		60kVA	80kVA	90kVA	100kVA	120kVA	150kVA	200kVA	
Main Input	Main Input Current(A)		96	128	144	159	191	239	319
	CableSection (mm <sup>2</sup> )	A	25	35	35	50	70	95	120
		B	25	35	35	50	70	95	120
		C	25	35	35	50	70	95	120
		N	25	35	35	50	70	95	120
Main Output	Main Output Current(A)		91	121	136	152	182	227	303
	CableSection (mm <sup>2</sup> )	A	25	35	35	50	70	70	120
		B	25	35	35	50	70	70	120
		C	25	35	35	50	70	70	120
		N	25	35	35	50	70	70	120
Bypass Input (Optional)	Bypass Input Current(A)		91	121	136	152	182	227	303
	CableSection (mm <sup>2</sup> )	A	25	35	35	50	70	70	120
		B	25	35	35	50	70	70	120
		C	25	35	35	50	70	70	120
		N	25	35	35	50	70	70	120
Battery Input	Battery Input current(A)		125	167	188	208	250	313	417
	CableSection (mm <sup>2</sup> )	+	35	50	70	70	95	120	185
		-	35	50	70	70	95	120	185
		N	35	50	70	70	95	120	185
PE	CableSection (mm <sup>2</sup> )	PE	50	50	70	70	95	120	185
Contents		250kVA	300kVA	400kVA	500kVA				
Main Input	Main Input Current(A)		398	478	638	797			
	CableSection (mm <sup>2</sup> )	A	185	185	2*150	2*185			
		B	185	185	2*150	2*185			
		C	185	185	2*150	2*185			
		N	185	185	2*150	2*185			
Main Output	Main Output Current(A)		379	454	606	758			
	CableSection (mm <sup>2</sup> )	A	185	185	2*150	2*185			
		B	185	185	2*150	2*185			
		C	185	185	2*150	2*185			
		N	185	185	2*150	2*185			
Bypass Input (Optional)	Bypass Input Current(A)		379	454	606	758			
	CableSection (mm <sup>2</sup> )	A	185	185	2*150	2*185			
		B	185	185	2*150	2*185			
		C	185	185	2*150	2*185			
		N	185	185	2*150	2*185			
Battery Input	Battery Input current(A)		521	626	833	1042			
	CableSection (mm <sup>2</sup> )	+	240	240	2*185	2*240			
		-	240	240	2*185	2*240			
		N	240	240	2*185	2*240			
PE	CableSection (mm <sup>2</sup> )	PE	2*120	2*120	2*150	2*150			

 **Note**

The recommended cable section for power cables are only for situations described below:

Ambient temperature: 30°C.

AC loss less than 3%, DC loss less than 1%, The length of the AC power cables are no longer than 50 m and the length of the DC power cables are no longer than 30 m.

Currents listed in the table are based on the 380V system (Line-to-line voltage).

The size of neutral lines should be 1.5~1.7 times the value listed above when the predominant load is non-linear.

## 2.6.2 Specifications for Power Cables Terminal

Specifications for power cables connector are listed as Table 2-3.

Type	Port	Connection	Bolt	Torque Moment
60kVA	Mains input	Cables crimped OT terminal	M6	4.9Nm
	Bypass Input	Cables crimped OT terminal	M6	4.9Nm
	Battery Input	Cables crimped OT terminal	M6	4.9Nm
	Output	Cables crimped OT terminal	M6	4.9Nm
	PE	Cables crimped OT terminal	M6	4.9Nm
90kVA 120kVA	Mains input	Cables crimped OT terminal	M6	4.9Nm
	Bypass Input	Cables crimped OT terminal	M6	4.9Nm
	Battery Input	Cables crimped OT terminal	M6	4.9Nm
	Output	Cables crimped OT terminal	M6	4.9Nm
	PE	Cables crimped OT terminal	M6	4.9Nm
80kVA 100kVA	Mains input	Cables crimped OT terminal	M6	4.9Nm
	Bypass Input	Cables crimped OT terminal	M6	4.9Nm
	Battery Input	Cables crimped OT terminal	M8	13Nm
	Output	Cables crimped OT terminal	M6	4.9Nm
	PE	Cables crimped OT terminal	M6	4.9Nm
150kVA 200kVA	Mains input	Cables crimped OT terminal	M10	15Nm
	Bypass Input	Cables crimped OT terminal	M10	15Nm
	Battery Input	Cables crimped OT terminal	M10	15Nm
	Output	Cables crimped OT terminal	M10	15Nm
	PE	Cables crimped OT terminal	M10	15Nm
250kVA 300kVA	Mains input	Cables crimped OT terminal	M12	28Nm
	Bypass Input	Cables crimped OT terminal	M12	28Nm
	Battery Input	Cables crimped OT terminal	M12	28Nm
	Output	Cables crimped OT terminal	M12	28Nm
	PE	Cables crimped OT terminal	M12	28Nm
400kVA 500kVA	Mains input	Cables crimped OT terminal	M16	96Nm
	Bypass Input	Cables crimped OT terminal	M16	96Nm
	Battery Input	Cables crimped OT terminal	M16	96Nm
	Output	Cables crimped OT terminal	M16	96Nm
	PE	Cables crimped OT terminal	M16	96Nm

### 2.6.3 Circuit Breaker

The circuit breakers (CB) for the system are recommended in Table 2-4.

Table 2-4 Recommended CB

Installed position	60kVA	80kVA	90kVA	100kVA	120kVA	150kVA
Main input CB	125A/3P	160A/3P	160A/3P	250A/3P	250A/3P	320A/3P
Bypass input CB	125A/3P	160A/3P	160A/3P	250A/3P	250A/3P	320A/3P
Output CB	125A/3P	160A/3P	160A/3P	250A/3P	250A/3P	320A/3P
Manual Bypass CB	125A/3P	160A/3P	160A/3P	250A/3P	250A/3P	320A/3P
Battery CB	160A, 250Vdc	225A, 250Vdc	225A, 250Vdc	250A, 250Vdc	400A, 250Vdc	400A, 250Vdc
Installed position	200kVA	250kVA	300kVA	400kVA	500kVA	
Main input CB	400A/3P	630A/3P	630A/3P	800A/3P	800A/3P	
Bypass input CB	400A/3P	630A/3P	630A/3P	800A/3P	800A/3P	
Output CB	400A/3P	630A/3P	630A/3P	800A/3P	800A/3P	
Manual Bypass CB	400A/3P	630A/3P	630A/3P	800A/3P	800A/3P	
BatteryCB	630A, 250Vdc	800A/3P 250Vdc	1000A/3P 250Vdc	1000A, 250Vdc	1250A, 250Vdc	



#### Attention

The CB with RCD (Residual Current Device) is not suggested for the system.

### 2.6.4 Connecting Power Cables

The steps of connecting power cables are as follows:

- 1) Verify that all the switches of the UPS are completely open and the UPS internal maintenance bypass switch is opened. Attach necessary warning signs to these switches to prevent unauthorized operation.
- 2) Open the front door of the cabinet(400kVA and 500kVA open the back door), remove the plastic cover. The input and output terminal, battery terminal and protective earth terminal are shown in Figure2-9.

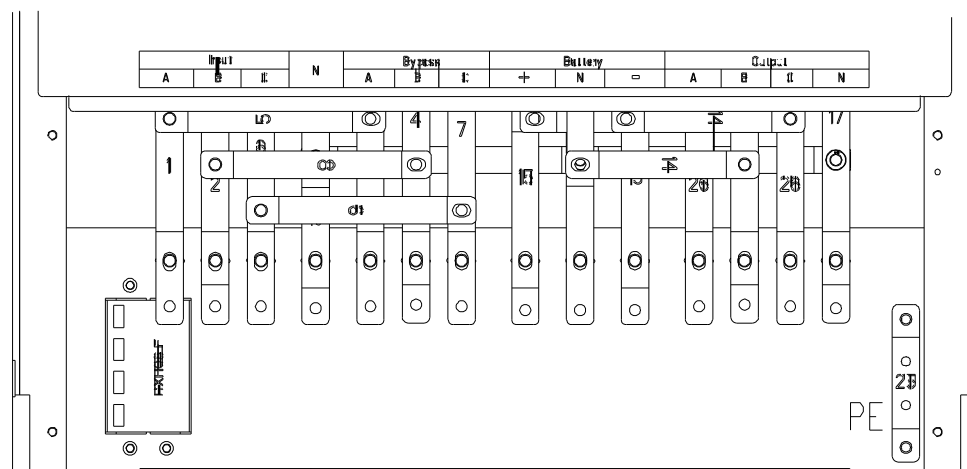

(a) Connections terminals of 60kVA, 90kVA and 120kVA

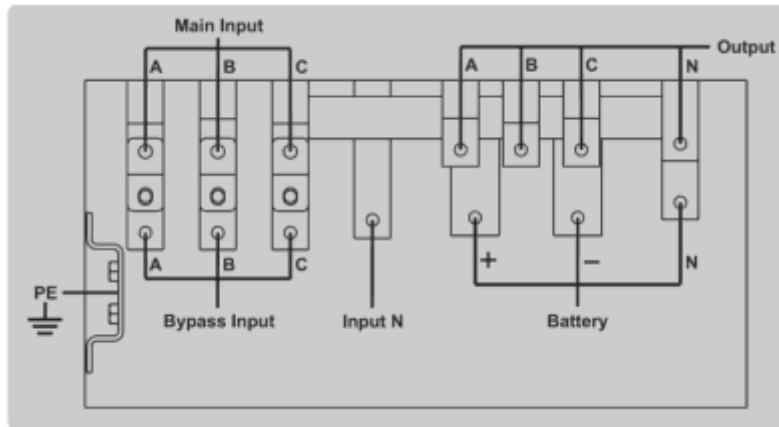

(b) Connections terminals of 150kVA and 200kVA

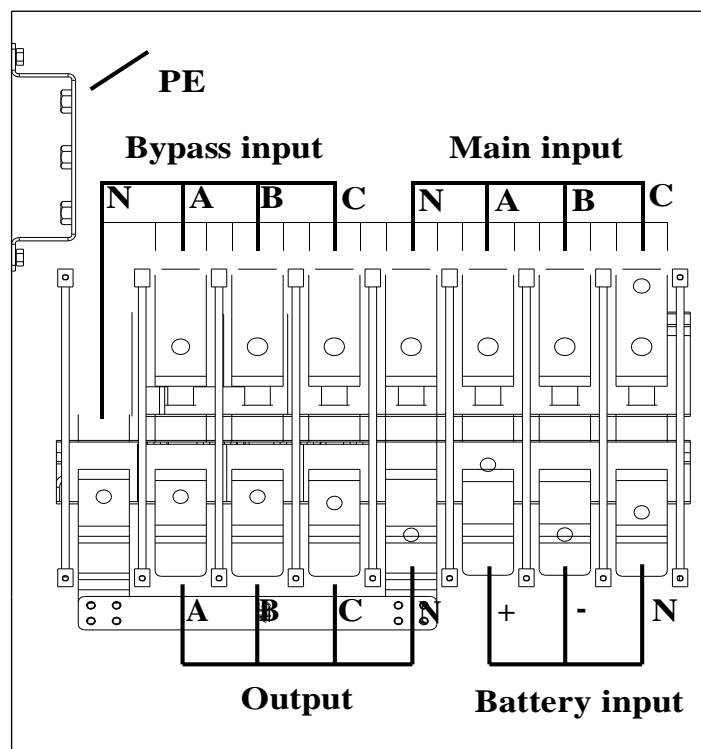

(c) Connections terminals of 250kVA and 300kVA

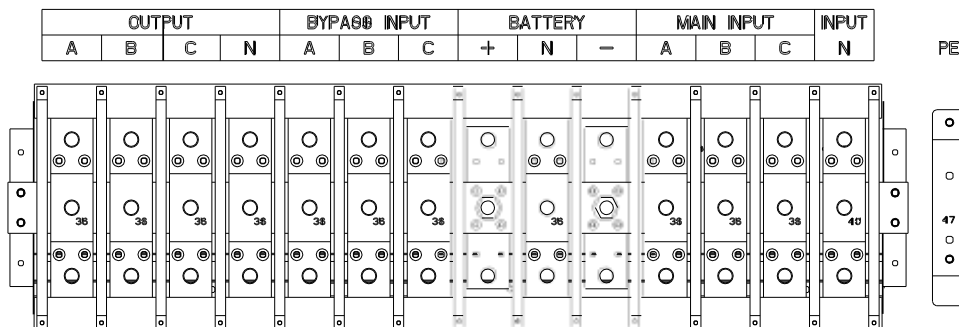

(d) Connections terminals of 400kVA and 500kVA

Figure2-9 Connections terminals

- 3) Connect the protective earth wire to protective earth terminal (PE).
- 4) Connect the AC input supply cables to the Input terminal and AC output supply cables to the Output terminal.
- 5) Connect the Battery cables to the Battery terminal.
- 6) Check to make sure there is no mistake and re-install all the protective covers.



**Attention**

The operations described in this section must be performed by authorized electricians or qualified technical personnel. If you have any difficulties, contact the manufacturer or agency.



**Warning**

Tighten the connections terminals to enough torque moment, refer to Table 2-3, and please ensure correct phase rotation.

The grounding cable and neutral cable must be connected in accordance with local and national codes.

Load must be connected to the same ground as that of UPS system

## 2.7 Control and Communication Cables

The front panel of the bypass module provides dry contact interface (J2-J11) and communication interface (RS232, RS485, SNMP, Intelligent card interface and USB port), as it is shown in Figure2-10.

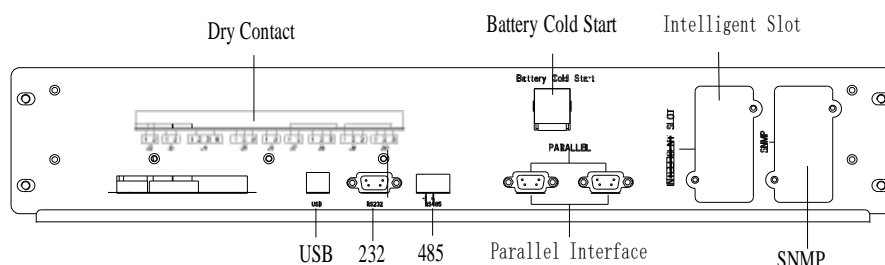

(a) Dry contact & communication interface of 60kVA-300kVA

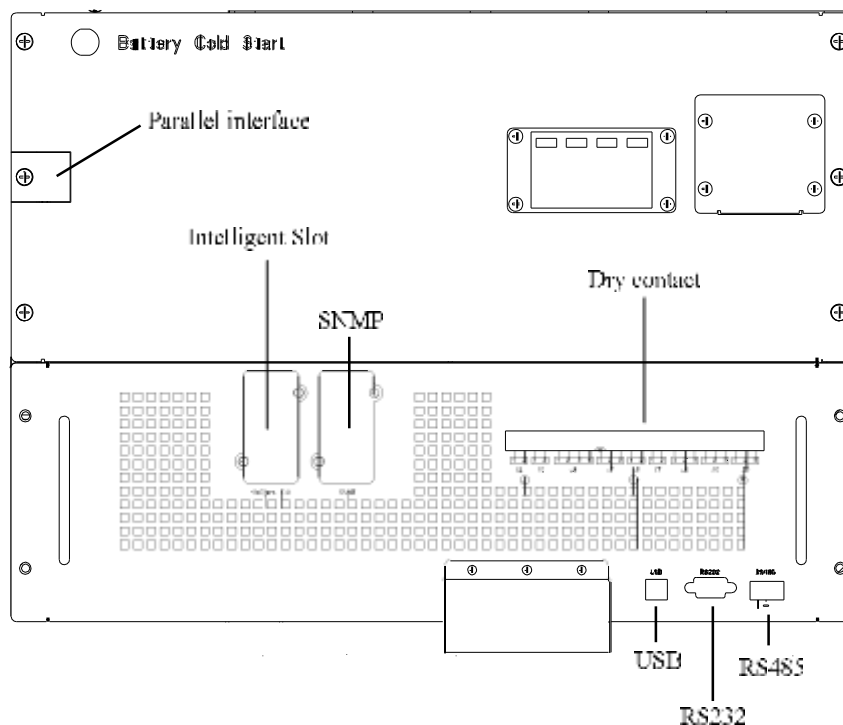

(a) Dry contact & communication interface of 400kVA and 500kVA

Figure2-10Dry contact & communication interface

### 2.7.1 Dry Contact Interface

Dry contact interface includes port J2-J11 and the functions of the dry contact are shown in Table 2-5.

Table 2-5Functions of the port

Port	Name	Function
J2-1	TEMP_BAT	Detection of battery temperature
J2-2	TEMP_COM	Common terminal for temperature detection
J3-1	ENV_TEMP	Detection of environmental temperature
J3-2	TEMP_COM	Common terminal for temperature detection
J4-1	REMOTE_EPO_NC	Trigger EPO when disconnect with J4-2
J4-2	+24V_DRY	+24V
J4-3	+24V_DRY	+24V
J4-4	REMOTE_EPO_NO	Trigger EPO when shorted with J4-3
J5-1	+24V_DRY	+24V
J5-2	GEN_CONNECTED	Input dry contact , function is settable , Default: interface for generator
J5-3	GND_DRY	Ground for +24V
J6-1	BCB Drive	Output dry contact, function is settable. Default: Battery trip signal

J6-2	BCB_Status	Input dry contact, function is settable. Default: BCB Status and BCB Online, (Alert no battery when BCB Status is invalid).
J7-1	GND_DRY	Ground for +24V
J7-2	BCB_Online	Input dry contact, function is settable. Default: BCB Status and BCB Online (Alert no battery when BCB Status is invalid).
J8-1	BAT_LOW_ALARM_NC	Output dry contact (Normally closed), function is settable. Default: Low battery alarming
J8-2	BAT_LOW_ALARM_NO	Output dry contact (Normally open), function is settable. Default: Low battery alarming
J8-3	BAT_LOW_ALARM_GND	Common terminal for J8-1 and J8-2
J9-1	GENERAL_ALARM_NC	Output dry contact, (Normally closed) function is settable. Default: Fault alarming
J9-2	GENERAL_ALARM_NO	Output dry contact, (Normally open) function is settable. Default: Fault alarming
J9-3	GENERAL_ALARM_GND	Common terminal for J9-1 and J9-2
J10-1	UTILITY_FAIL_NC	Output dry contact, (Normally closed) function is settable. Default: Utility abnormal alarming
J10-2	UTILITY_FAIL_NO	Output dry contact, (Normally open) function is settable. Default: Utility abnormal alarming
J10-3	UTILITY_FAIL_GND	Common terminal for J10-1 and J10-2

#### Note

The settable functions for each port can be set by the monitor software.

The default functions of each port are described as follows.

#### **Battery Warning Output Dry Contact Interface**

The input dry contact J2 and J3 can detect the temperature of batteries and environment respectively, which can be used in environment monitoring and battery temperature compensation. Interfaces diagram for J2 and J3 are shown in Figure2-11, the description of interface is in Table 2-6.

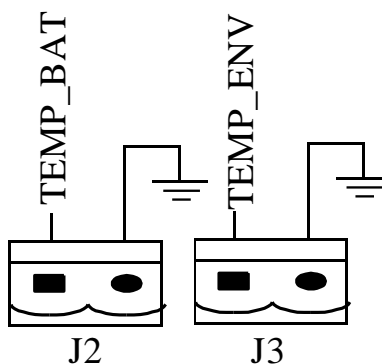

Figure2-11J2 and J3 for temperature detecting

Table 2-6Description of J2 and J3

Port	Name	Function
J2-1	TEMP_BAT	Detection of battery temperature
J2-2	TEMP_COM	common terminal
J3-1	ENV_TEMP	Detection of environmental temperature
J3-2	TEMP_COM	common terminal

**Note**

Specified temperature sensor is required for temperature detection (R25=5Kohm, B25/50=3275), please confirm with the manufacturer, or contact the local maintenance engineers when placing an order.

**Remote EPO Input Port**

J4 is the input port for remote EPO. It requires shorting NC and +24V and disconnecting NO and +24V during normal operation, and the EPO is triggered when opening NC and +24V or shorting the NO and +24V. The port diagram is shown in Figure2-12 and port description is shown in Table 2-7.

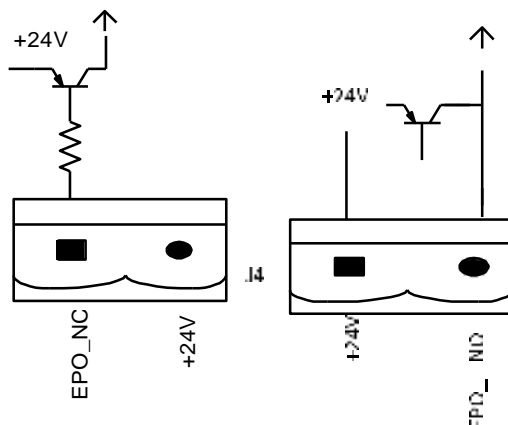

Figure2-12Diagram of input port for remote EPO

Table 2-7Description of input port for remote EPO

Port	Name	Function
J4-1	REMOTE_EPO_NC	Trigger EPO when disconnect with J4-2
J4-2	+24V_DRY	+24V
J4-3	+24V_DRY	+24V
J4-4	REMOTE_EPO_NO	Trigger EPO when connect with J4-3

### Generator Input Dry Contact

The default function of J5 is the interface for generator J5 Connect pin 2 of J5 with +24V power supply; it indicates that the generator has been connected with the system. The interface diagram is shown in Figure2-13, and interface description is shown in Table 2-8.

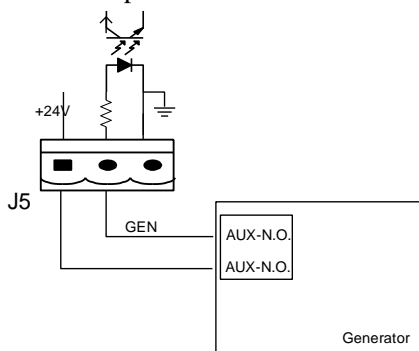

Figure2-13Diagram of status interface and connection of generator

Table 2-8Description of status interface and connection of generator

Port	Name	Function
J5-1	+24V_DRY	+24V
J5-2	GEN_CONNECTED	Connection status of generator
J5-3	GND_DRY	Power ground for +24V

### BCB Input Port

The default function of J6 and J7 are the ports of BCB. The port diagram is shown in Figure2-14, and description is shown in Table 2-9.

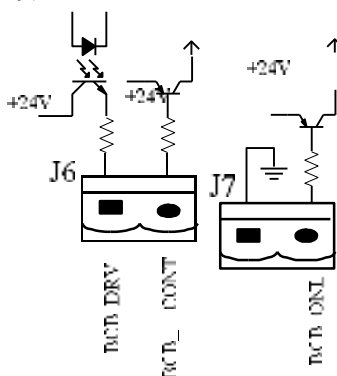

Figure2-14BCB Port

Table 2-9Description of BCB port

Port	Name	Function
J6-1	BCB_DRIV	BCB contact drive, provides +24V voltage, 20mA drive signal
J6-2	BCB_Status	BCB contact status, connect with the normally open signal of BCB
J7-1	GND_DRY	Power ground for +24V
J7-2	BCB_Online	BCB on-line input (normally open) , BCB is on-line when the signal is connecting with J7-1

### Battery Warning Output Dry Contact Interface

The default function of J8 is the output dry contact interface, which presents the battery warnings of low or excessive voltage, when the battery voltage is lower than set value, an auxiliary dry contact signal will be activated via the isolation of a relay. The interface diagram is shown in

Figure2-15, and description is shown in Table 2-10.

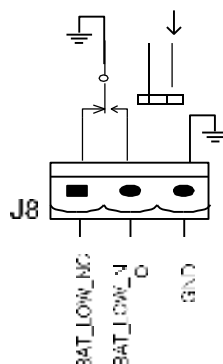

Figure2-15Battery warning dry contact interface diagram

Table 2-10Battery warning dry contact interface description

Port	Name	Function
J8-1	BAT_LOW_ALARM_NC	Battery warning relay (normally closed) will be open during warning
J8-2	BAT_LOW_ALARM_NO	Battery warning relay (normally open) will be closed during warning
J8-3	BAT_LOW_ALARM_GND	Common terminal

**General Alarm Output Dry Contact Interface**

The default function of J9 is the general alarm output dry contact interface. When one or more warnings are triggered, an auxiliary dry contact signal will be active via the isolation of a relay. The interface diagram is shown in Figure2-16, and description is shown in Table 2-11.

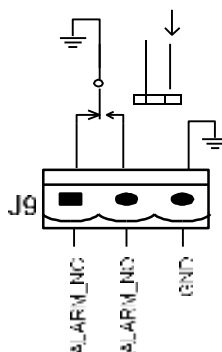

Figure2-16Integrated warning dry contact interface diagram

Table 2-11General alarm dry contact interface description

Port	Name	Function
J9-1	GENERAL_ALARM_NC	Integrated warning relay (normally closed) will be open during warning
J9-2	GENERAL_ALARM_NO	Integrated warning relay (normally open) will be closed during warning
J9-3	GENERAL_ALARM_GND	Common terminal

**Utility Fail Warning Output Dry Contact Interface**

The default function of J10 is the output dry contact interface for utility failure warning, when the utility fails, the system will send a utility failure warning information, and provide an auxiliary dry contact signal via the isolation of a relay. The interface diagram is shown in Figure2-17, and description is shown in Table 2-12.

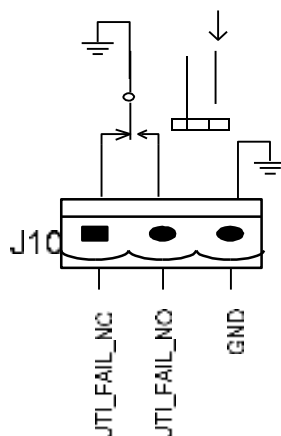

Figure 2-17 Utility failure warning dry contact interface diagram

Table 2-12 Utility failure warning dry contact interface description

Port	Name	Function
J10-1	UTILITY_FAIL_NC	Mains failure warning relay (normally closed) will be open during warning
J10-2	UTILITY_FAIL_NO	Mains failure warning relay (normally open) will be closed during warning
J10-3	UTILITY_FAIL_GND	Common terminal

### 2.7.2 Communication Interface

RS232, RS485 and USB port: Provide serial data which can be used for commissioning and maintenance by authorized engineers or can be used for networking or integrated monitoring system in the service room.

SNMP: Used on site installation for communication (Optional).

Intelligent card interface: Extension dry contact interface (Optional).

## 3 Operator Control and Display Panel

### 3.1 UPS operator panel

The structure of operator control and display panel for cabinet is shown in Figure3-1.

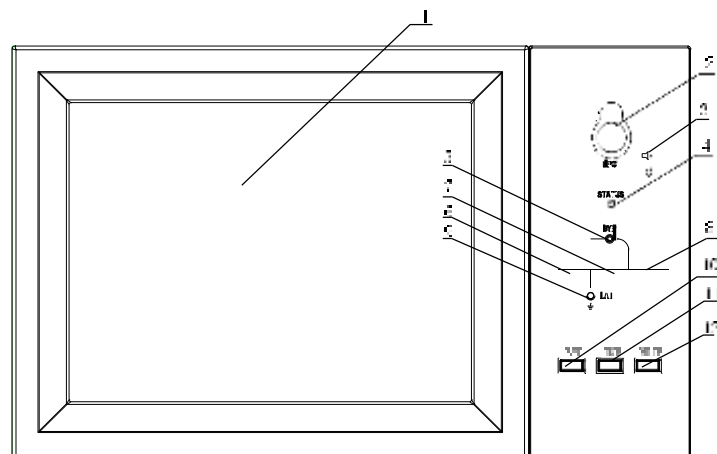

- |                       |                       |                           |
|-----------------------|-----------------------|---------------------------|
| 1: LCD touch screen   | 2: EPO switch         | 3: Audible Alarm (Buzzer) |
| 4: Status indicator   | 5: Bypass indicator   | 6: Rectifier indicator    |
| 7: Inverter indicator | 8: Load indicator     | 9: Battery indicator      |
| 10: Bypass transfer   | 11: Inverter transfer | 12: Mute                  |

Figure3-1 Control and display panel

The LCD panel for cabinet is divided into three functional areas: LED indicator, control and operation keys and LCD touch screen.

#### 3.1.1 LED Indicator

There are 6 LEDs on the panel to indicate the operating status and fault. (See Figure 4-1).The description of indicators is shown in Table 3-1

Table 3-1 Status description of indicator

Indicator	State	Description
Rectifier indicator	Steady green	Rectifier normal for all modules
	Flashing green	Rectifier normal for at least one module, mains normal
	Steady red	Rectifier fault
	Flashing red	Mains abnormal for at least one module
	Off	Rectifier not operating
Battery indicator	Steady green	Battery charging
	Flashing green	Battery discharging
	Steady red	Battery abnormal (battery failure, no battery or battery reversed) or battery converter abnormal (failure, over current or over temperature) , EOD
	Flashing red	Battery low voltage

Indicator	State	Description
	Off	Battery and battery converter normal, battery not charging
Bypass indicator	Steady green	Load supplied by bypass
	Steady red	Bypass abnormal or out of normal range, or static bypass switch fault
	Flashing red	Bypass voltage abnormal
	Off	Bypass normal
Inverter indicator	Steady green	Load supplied by inverter
	Flashing green	Inverter on, start, synchronization or standby (ECO mode) for at least one module
	Steady red	System output not supplied by inverter, inverter fault for at least one module.
	Flashing red	System output supplied by inverter, inverter fault for at least one module.
	Off	Inverter not operating for all modules
Load indicator	Steady green	UPS output ON and normal
	Steady red	UPS overload time is out, or output short, or output no power supply
	Flashing red	Overload output of UPS
	Off	No output of UPS
Status indicator	Steady green	Normal operation
	Steady red	Failure

There are two different types of audible alarm during UPS operation, as shown in Table 3-2.

Table 3-2 Description of audible alarm

Alarm	Description
Two short alarm with a long one	when system has general alarm (for example: AC fault),
Continuous alarm	When system has serious faults (for example: fuse blown or hardware failure)

### 3.1.2 Control and Operation Keys

Control and operation keys include four keys of 2, 10, 11 and 12(See Figure3-1), which are used together with LCD touch screen. The functions description is shown in Table 3-3.

Function Key	Description
EPO	Long press, cut off the load power (shut down the rectifier, inverter, static bypass and battery)
BYP	Long press, transfer to the bypass(Push the button up in the back of the door to enable , see Figure4.2)
INV	Long press, transfer to the inverter
MUTE	Long press to switch between turning off and on the buzzing

### 3.1.3 LCD touch Screen

Users can easily browse the information, operate the UPS, and set the parameters through the LCD touchscreen, which is friendly for users.

After the monitoring system starts self-test, the system enters the home page, following the welcome window. The home page is shown in Figure3-2.

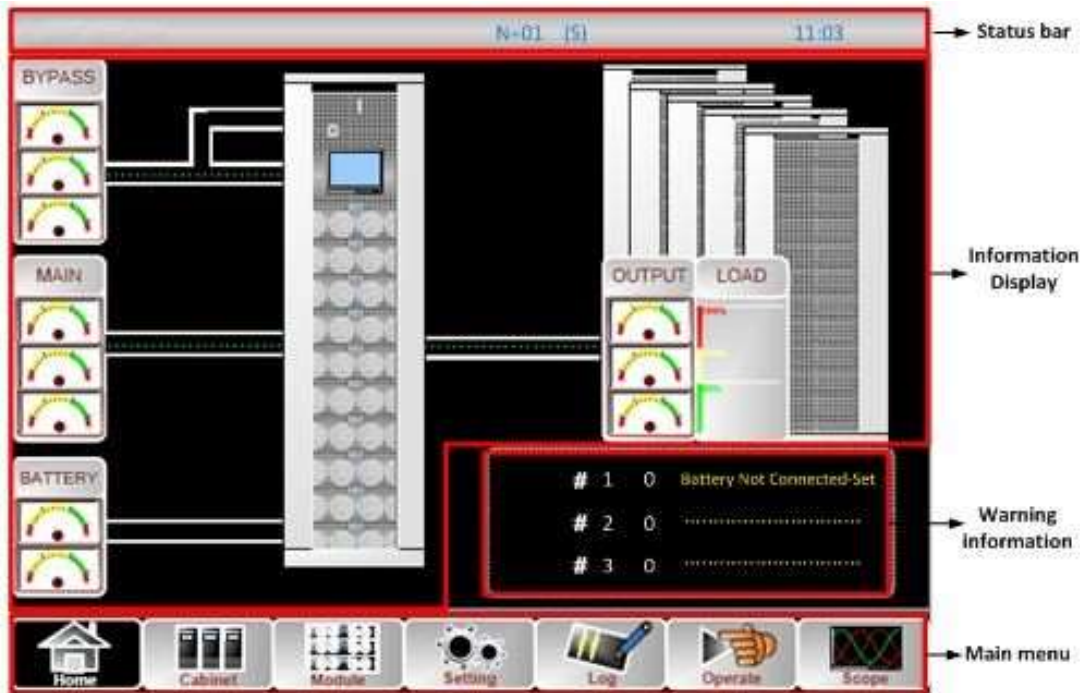

Figure3-2 Home page

Home page consists of Status bar, Information display, warning information and main menu.

#### Status bar

The Status bar contains the model of the product, capacity, operational mode, and the number of the power module and the time of the system.

#### Warning Information

Display the warning information of the cabinet.

#### Information Display

Users can check the information of the cabinet in this area.

The bypass voltage, main input voltage, battery voltage, and output voltages are presented in the form of gauge.

The loads are displayed in the form of bar chart in percentage. The green area stands for a load of less than 60%, yellow area for a load of 60%-100% and red area for a load of more than 100%.

The energy flow mimics the flow of the power.

#### Main Menu

The main menu includes Cabinet, Power unit, setting, log, Operate and Scope. Users can operate and control the UPS, and browse all measured parameters through main menu.

The structure of the main menu tree is shown in Figure3-3.

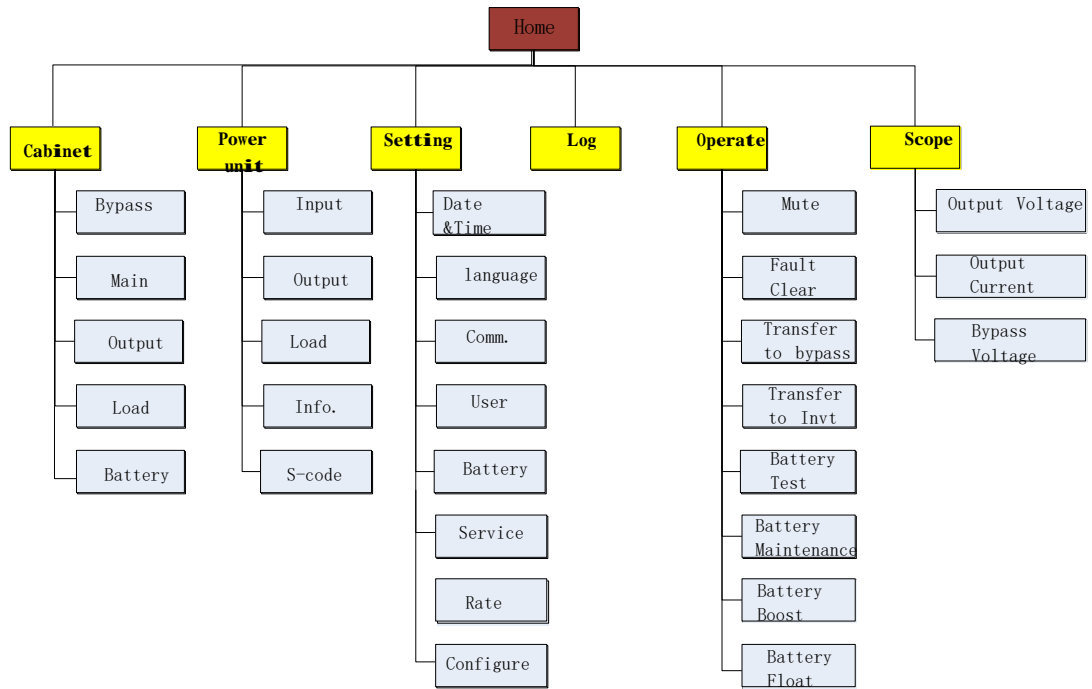



Figure3-3 Structure of menu tree

### 3.2 Main Menu

The main menu includes Cabinet, Power unit, Setting, Log, Operate and Scope and it is described in details below.

#### 3.2.1 Cabinet

Touch the icon  (At the bottom left of the screen), and the system enters the page of the Cabinet, as it is shown in Figure3-4.

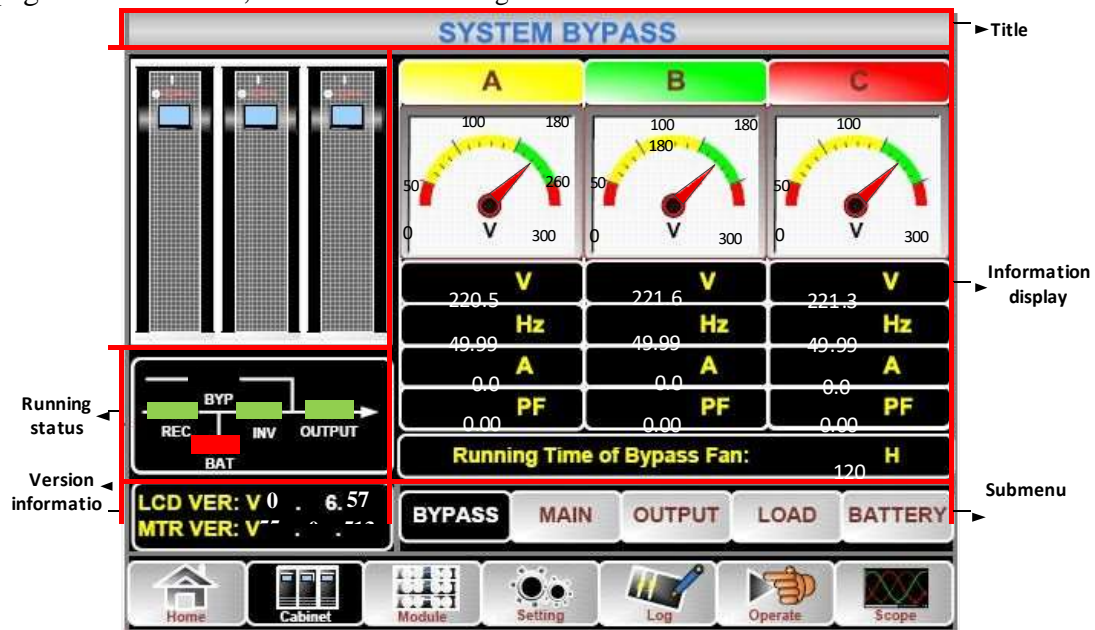

Figure3-4 Cabinet

The Cabinet comprises sectors of title, information display, version running status, information

display and submenu. The sectors are described as follows.

**Title**

Display the information of the selected submenu.

**Running status**

The squares shown on the mini current path represent the various UPS power paths and show the current UPS operating status. (The green square indicating the block working normally, the white indicating the absent of the block and red indicating the absence of the block or in fault).

**Version Information**

The version information for LCD of the cabinet and monitor.

**Submenu**

It includes the submenu of Bypass, Main, Output, load and battery.

**Information display**

Display information of each submenu.

The interface of each submenu is shown in Figure3-5.

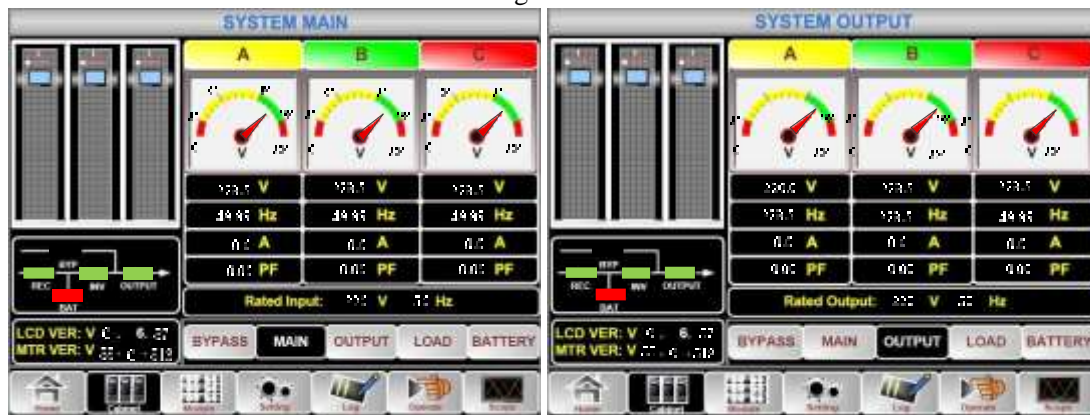

(a) Interface of Main

(b) Interface of Output



(d) Interface of Load

(d) Interface of Battery

Figure3-5 Submenu interface of Cabinet

The submenu of Cabinet is described in details below in Table 3-4.

Table 3-4 Description of each submenu of Cabinet

Submenu Name	Contents	Meaning
Main	V	Phase voltage
	A	Phase current
	Hz	Input frequency
	PF	Power factor
Bypass	V	Phase voltage
	A	Phase current

Submenu Name	Contents	Meaning
	Hz	Bypass frequency
	PF	Power factor
Output	V	Phase voltage
	A	Phase current
	Hz	Output frequency
	PF	Power factor
Load	kVA	Sout: Apparent Power
	kW	Pout: Active Power
	kVar	Qout: Reactive power
	%	Load (The percentage of the UPS load)
Battery	V	Battery positive/negative Voltage
	A	Battery positive/negative Current
	Capacity (%)	The percentage compared with new battery capacity
	Remain T (Min)	Remaining battery backup time
	Battery(°C)	Battery Temp
	Ambient(°C)	Environmental Temp
	Total Work T	Total work time
	Total Discharge T	Total discharging time

### 3.2.2 Power unit

Touch the icon  (At the bottom left of the screen), and the system enters the page of the Power unit, as is shown in Figure3-6.

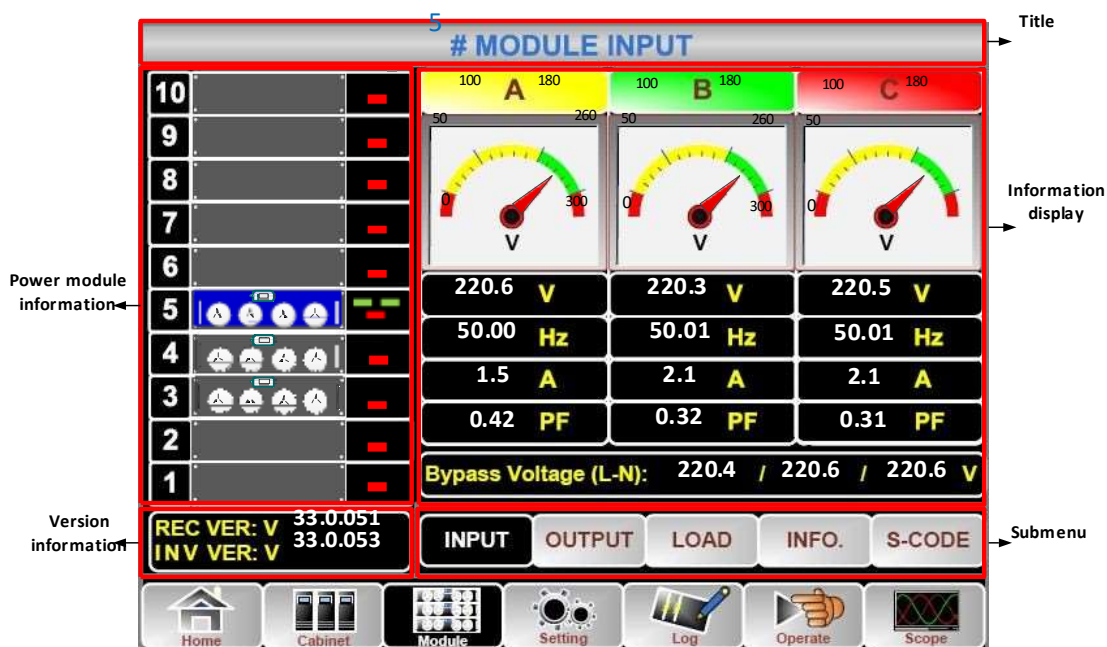

Figure3-6 Power unit

The module comprises sectors of title, information display, power unit information, version information and submenu. The sectors are described as follows.

**Title**

Present the title of submenu of the selected power unit.

**Information display**

Display information of each submenu.

**Power unit information**

The users can choose the power unit to browse the information in the “Information display” sector.

Colors of the square on the mimic current path represent the various power unit paths and show the current operating status.

- (a) The green square indicating the power unit working normally,
- (b) The black indicating power unit in invalid
- (c) The red indicating the absence of the power unit or in fault

Take the 5#power unit  for example. It indicates that UPS is in Normal mode and the rectifier and inverter are working normally .The battery is not connected.

**Version Information**

The version information for rectifier and inverter of the selected power unit.

**Submenu**

The submenu includes Input, Output, Load, INFO and S-CODE.

Users can enter the interface of each submenu by directly touching the icon .Each interface of the submenu is shown in Figure3-7.



(a) Interface of Output

(b) Interface of Load



(c) Interface of Information

(d) Interface of S-Code

Figure3-7 Module menu

The submenus of Power unit are described below in details in Table 3-5.

Table 3-5 Description of each submenu of Power unit

Submenu Name	Contents	Meaning
Input	V	Input phase voltage of selected module
	A	Input phase current of selected module
	Hz	Input frequency of selected module
	PF	Input power factor of selected module
Output	V	Output phase voltage of selected module
	A	Output phase current of selected module
	Hz	Output frequency of selected module
	PF	Output power factor of selected module
Load	V	Load voltage of selected module
	%	Load (The percentage of the power module selected)
	KW	Pout: Active Power
	KVA	Sout: Apparent Power
Information	BATT+(V)	Battery Voltage (positive)
	BATT-(V)	Battery Voltage (negative)
	BUS(V)	Bus Voltage(Positive &Negative)
	Charger(V)	Charger Voltage(Positive &Negative)
	Fan Time	Total Fan's Running time of the selected power module
	Inlet Temperature(°C)	Inlet Temperature of the selected power module
	Outlet Temperature(°C)	Outlet Temperature of the selected power module
S-code	Fault Code	For the maintenance personnel

### 3.2.3 Setting

Touch the icon  (At the bottom of the screen), and the system enters the page of the Setting, as it is shown in Figure3-8.

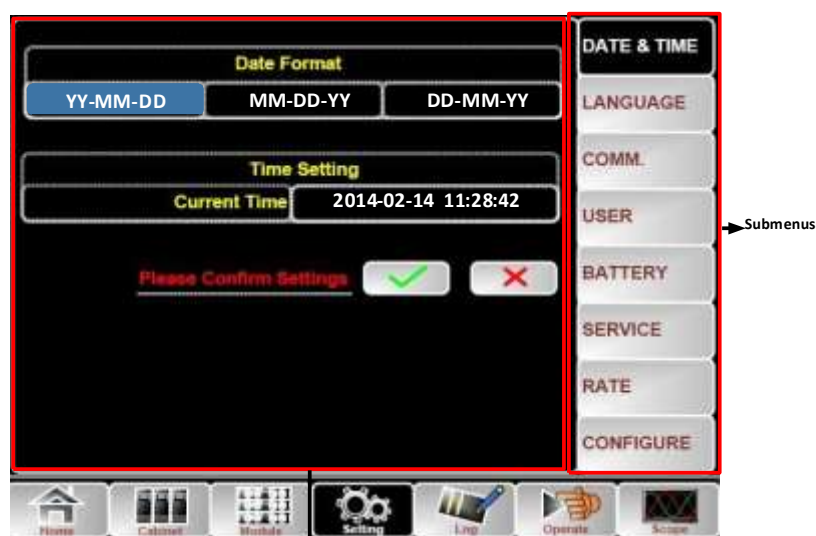

Setting interface  
Figure3-8 Setting menu

The submenus are listed on the right side of the Setting page. Users can enter each of the setting interfaces by touching the relevant icon. The submenus are described in details below in Table 3-6.

Table 3-6 Description of each submenu of Setting

Submenu Name	Contents	Meaning
Date & Time	Date format setting	Three formats: (a) year/month/day,(b) month/date/year, (c) date/month/year
	Time setting	Setting time
Language	Current language	Language in use
	Language selection	Simplified Chinese and English selectable (The setting taking action immediately after touching the language icon)
COMM.	Device Address	Setting the communication address
	RS232 Protocol Selection	SNT Protocol, Modbus Protocol, YD/T Protocol and Dwin (For factory use)
	Baud rate	Setting the baud rate of SNT, Modbus and YD/T
	Modbus Mode	Setting mode for Modbus: ASCII and RTU selectable
	Modbus parity	Setting the parity for Modbus
USER	Output voltage Adjustment	Setting the Output Voltage
	Bypass Voltage Up Limited	Up limited working Voltage for Bypass, settable:+10%, +15%, +20%, +25%
	Bypass Voltage Down Limited	Down limited working Voltage for Bypass, settable:-10%, -15%, -20%, -30%, -40%
	Bypass Frequency Limited	Permitted working Frequency for Bypass Settable: +-1Hz, +-3Hz, +-5Hz
	Dust Filter Maintenance Period	Setting Dust Filter Maintenance Period
BATTERY	Battery Number	Setting the number of the battery (12V)
	Battery Capacity	Setting of the AH of the battery
	Float Charge Voltage/Cell	Setting the floating Voltage for battery cell (2V)
	Boost Charge Voltage/Cell	Setting the boost Voltage for battery cell (2V)
	EOD(End of discharge) Voltage/Cell,@0.6C Current	EOD voltage for cell battery,@0.6C current
	EOD(End of charge) Voltage/Cell,@0.15C Current	EOD voltage for cell battery,@0.15C current
	Charge Current Percent Limit	Charge current (percentage of the rated current)
	Battery Temperature Compensate	Coefficient for battery temperature compensation
	Boost Charge Time Limit	Setting boost charging time
	Auto Boost Period	Setting the auto boost period

Submenu Name	Contents	Meaning
	Auto Maintenance Discharge Period	Setting the period for auto maintenance discharge
SERVICE	System Mode	Setting the system mode: Single , parallel, Single ECO, parallel ECO, LBS, parallel LBS
RATE	Configure the rated Parameter	For the factory use
CONFIGURE	Configure the system	For the factory use

**Note**

Users have various permissions to the configuration of the Setting :( a) for the Date &Time, LANGUAGE and COMM, user can set on their own without password. (b)For the USER, a one-level password is needed and the setting must be done by commissioning engineer (c) For the Battery and SERVICE, a Two-level password is needed and it is set by the after-service personal. (d)For the RATE and CONFIGURE, a Three-level password is needed and it is set only by the factory.

The “C” stands for Ampere number. For instance, if the battery is 100AH, then C=100A.



**Warning**

Ensure the number of the battery, set via the menu or the monitoring software, is completely equal to the real installed number. Otherwise it will cause serious damage to the batteries or the equipment.

**3.2.4 Log**



Touch the icon (At the bottom of the screen), and the system enters the interface of the Log, as it is shown in Figure3-9.The log is listed in reverse chronological order (i.e. the first on the screen with #1 is the most new), which displays the events ,warnings and faults information and the data and time they occur and disappear.

NO.	M# EVENTS	TIME
1	0 # Load On UPS-Set	2014 - 2 - 14 16 26 : 1
2	4 # Module Inserted-Set	2014 - 2 - 14 16 24 : 27
3	0 # Byp Freq Over TrackSet	2014 - 2 - 14 16 22 : 31
4	0 # Load On Bypass-Set	2014 - 2 - 14 16 21 : 33
5	0 # Bypass Volt AbnormalSet	2014 - 2 - 14 16 21 : 33
6	0 # Load On Bypass-Set	2014 - 2 - 14 16 19 : 41
7	0 # No Load-Set	2014 - 2 - 14 16 18 : 45
8	4 # Load On Bypass-Set	2014 - 2 - 14 16 18 : 45
9	0 # Byp Freq Over TrackSet	2014 - 2 - 14 16 18 : 45
10	4 # Module-Exit-Set	2014 - 2 - 14 16 26 : 1

Total Log Items 29

Figure3-9 Log menu

The follow Table 3-7 gives the complete list of all the UPS events displayed by history record window and current record window.

Table 3-7 UPS Event List

NO.	UPS events	Description
1	Fault Clear	Manually clear fault
2	Log Clear	Manually clear History log
3	Load On UPS	Inverter feeds load
4	Load On Bypass	Bypass feeds load
5	No Load	No load
6	Battery Boost	Charger is working in boost charging mode
7	Battery Float	Charger is working in float charging mode
8	Battery Discharge	Battery is discharging
9	Battery Connected	Battery is connected already
10	Battery Not Connected	Battery is not yet connected.
11	Maintenance CB Closed	Manual maintenance breaker is closed
12	Maintenance CB Open	Manual maintenance breaker is opened
13	EPO	Emergency Power Off
14	Module On Less	Available power module capacity is less then the load capacity. Please reduce the load capacity or add extra power module to make sure that the UPS capacity is big enough.
15	Generator Input	Generator is connected and a signal is sent to the UPS.
16	Utility Abnormal	Utility (Grid) is abnormal. Mains voltage or frequency exceeds the upper or lower limit and results in rectifier shutdown. Check the input phase voltage of rectifier.
17	Bypass Sequence Error	Bypass voltage Sequence is reverse. Check if input power cables are connected correctly.
18	Bypass Volt Abnormal	<p>This alarm is triggered by an inverter software routine when the amplitude or frequency of bypass voltage exceeds the limit. The alarm will automatically reset if the bypass voltage becomes normal.</p> <p>First check if relevant alarm exists, such as “bypass circuit breaker open”, “Byp Sequence Err” and “Ip Neutral Lost”. If there is any relevant alarm, first clear this alarm.</p> <p>1. Then check and confirm if the bypass voltage and frequency displayed on the LCD are within the setting range. Note that the rated voltage and frequency are respectively specified by “Output Voltage” and “Output Frequency”.</p> <p>2. If the displayed voltage is abnormal, measure the actual bypass voltage and frequency. If the measurement is abnormal, check the external bypass power supply. If the alarm occurs frequently, use the configuration software to increase the bypass high limit set point according to the user’s suggestions</p>

19	Bypass Module Fail	Bypass Module Fails. This fault is locked until power off. Or bypass fans fail.
20	Bypass Module Over Load	Bypass current is over the limitation. If bypass current is under 135% of the rated current. The UPS alarms but has no action.
21	Bypass Over Load Tout	The bypass overload status continues and the overload times out.
22	Byp Freq Over Track	<p>This alarm is triggered by an inverter software routine when the frequency of bypass voltage exceeds the limit. The alarm will automatically reset if the bypass voltage becomes normal.</p> <p>First check if relevant alarm exists, such as “bypass circuit breaker open”, “Byp Sequence Err” and “Ip Neutral Lost”. If there is any relevant alarm, first clear this alarm.</p> <ol style="list-style-type: none"> <li>1. Then check and confirm if the bypass frequency displayed on the LCD are within the setting range. Note that the rated frequency are respectively specified by “Output Frequency”.</li> <li>2. If the displayed voltage is abnormal, measure the actual bypass frequency. If the measurement is abnormal, check the external bypass power supply. If the alarm occurs frequently, use the configuration software to increase the bypass high limit set point according to the user’s suggestions</li> </ol>
23	Exceed Tx Times Lmt	The load is on bypass because the output overload transfer and re-transfer is fixed to the set times during the current hour. The system can recover automatically and will transfer back to the inverter with 1 hour
24	Output Short Circuit	<p>Output shorted Circuit.</p> <p>Fist check and confirm if loads have something wrong.</p> <p>Then check and confirm if there is something wrong with terminals, sockets or some other power distribution unit.</p> <p>If the fault is solved, press “Fault Clear” to restart UPS.</p>
25	Battery EOD	Inverter turned off due to low battery voltage. Check the mains power failure status and recover the mains power in time
26	Battery Test	System transfer to battery mode for 20 seconds to check if batteries are normal
27	Battery Test OK	Battery Test OK
28	Battery Maintenance	System transfer to battery mode until to be 1.1*EOD voltage to maintenance battery string
29	Battery Maintenance OK	Battery maintenance succeed
30	Module inserted	Power Module is inserted in system.
31	Module Exit	Power Module is pulled out from system.
32	Rectifier Fail	The N# Power Module Rectifier Fail, The rectifier is fault and results in rectifier shutdown and battery discharging.
33	Inverter Fail	The N# Power Module Inverter Fail. The inverter output voltage is abnormal and the load transfers to bypass.
34	Rectifier Over	The N# Power Module Rectifier Over Temperature. The

	Temp.	<p>temperature of the rectifier IGBTs is too high to keep rectifier running. This alarm is triggered by the signal from the temperature monitoring device mounted in the rectifier IGBTs. The UPS recovers automatically after the over temperature signal disappears.</p> <p>If over temperature exists, check:</p> <ol style="list-style-type: none"> <li>1. Whether the ambient temperature is too high.</li> <li>2. Whether the ventilation channel is blocked.</li> <li>3. Whether fan fault happens.</li> <li>4. Whether the input voltage is too low.</li> </ol>
35	Fan Fail	At least one fan fails in the N# power module.
36	Output Over load	<p>The N# Power Module Output Over Load. This alarm appears when the load rises above 100% of nominal rating. The alarm automatically resets once the overload condition is removed.</p> <ol style="list-style-type: none"> <li>1. Check which phase has overload through the load (%) displayed in LCD so as to confirm if this alarm is true.</li> <li>2. If this alarm is true, measure the actual output current to confirm if the displayed value is correct.</li> </ol> <p>Disconnect non-critical load. In parallel system, this alarm will be triggered if the load is severely imbalanced.</p>
37	Inverter Overload Tout	<p>N# Power Module Inverter Over Load Timeout. The UPS overload status continues and the overload times out.</p> <p>Note:</p> <p>The highest loaded phase will indicate overload timing-out first. When the timer is active, then the alarm “unit over load” should also be active as the load is above nominal.</p> <p>When the time has expired, the inverter Switch is opened and the load transferred to bypass.</p> <p>If the load decreases to lower than 95%, after 2 minutes, the system will transfer back to inverter mode. Check the load (%) displayed in LCD so as to confirm if this alarm is true. If LCD displays that overload happens, then check the actual load and confirm if the UPS has over load before alarm happens.</p>
38	Inverter Over Temp.	<p>The N# Power Module Inverter Over Temperature.</p> <p>The temperature of the inverter heat sink is too high to keep inverter running. This alarm is triggered by the signal from the temperature monitoring device mounted in the inverter IGBTs. The UPS recovers automatically after the over temperature signal disappears.</p> <p>If over temperature exists, check:</p> <ul style="list-style-type: none"> <li>Whether the ambient temperature is too high.</li> <li>Whether the ventilation channel is blocked.</li> <li>Whether fan fault happens.</li> <li>Whether inverter overload time is out.</li> </ul>
39	On UPS Inhibited	<p>Inhibit system transfer from bypass to UPS (inverter). Check:</p> <ul style="list-style-type: none"> <li>Whether the power module’s capacity is big enough for load.</li> <li>Whether the rectifier is ready.</li> </ul>

		Whether the bypass voltage is normal.
40	Manual Transfer Byp	Transfer to bypass manually
41	Esc Manual Bypass	Escape from “transfer to bypass manually” command. If UPS has been transferred to bypass manually, this command enable UPS to transfer to inverter.
42	Battery Volt Low	Battery Voltage is Low. Before the end of discharging, battery voltage is low warning should occur. After this pre-warning, battery should have the capacity for 3 minutes discharging with full load.
43	Battery Reverse	Battery cables are connected not correctly.
44	Inverter Protect	The N# Power Module Inverter Protect. Check: Whether inverter voltage is abnormal Whether inverter voltage is much different from other modules, if yes, please adjust inverter voltage of the power module separately.
45	Input Neutral Lost	The mains neutral wire is lost or not detected. For 3 phases UPS, it’s recommended that user use a 3-poles breaker or switch between input power and UPS.
46	Bypass Fan Fail	At least one of bypass module Fans Fails
47	Manual Shutdown	The N# Power Module is manually shutdown. The power module shuts down rectifier and inverter, and there’s on inverter output.
48	Manual Boost Charge	Manually force the Charger work in boost charge mode.
49	Manual Float Charge	Manually force the charger work in float charge mode.
50	UPS Locked	Forbidden to shutdown UPS power module manually.
51	Parallel Cable Error	Parallel cables error. Check: If one or more parallel cables are disconnected or not connected correctly If parallel cable round is disconnected If parallel cable is OK
53	Lost N+X Redundant	Lost N+X Redundant. There is no X redundant powers module in system.
54	EOD Sys Inhibited	System is inhibited to supply after the battery is EOD (end of discharging)
55	Battery Test Fail	Battery Test Fail. Check if UPS is normal and battery voltage is over 90% of float voltage.
56	Battery Maintenance Fail	Check If UPS is normal and not any alarms If the battery voltage is over 90% of float voltage If load is over 25%
57	Ambient Over Temp	Ambient temperature is over the limit of UPS. Air conditioners are required to regulate ambient temperature.
58	REC CAN Fail	Rectifier CAN bus communication is abnormal. Please check if communication cables are not connected correctly.
59	INV IO CAN Fail	IO signal communication of inverter CAN bus is abnormal. Please

		check if communication cables are not connected correctly.
60	INV DATA CAN Fail	DATA communication of inverter CAN bus is abnormal. Please check if communication cables are not connected correctly.
61	Power Share Fail	The difference of two or more power modules' output current in system is over limitation. Please adjust output voltage of power modules and restart UPS.
62	Sync Pulse Fail	Synchronization signal between modules is abnormal. Please check if communication cables are not connected correctly.
63	Input Volt Detect Fail	Input voltage of N# power module is abnormal. Please check if the input cables are connected correctly. Please check if input fuses are broken. Please check if utility is normal.
64	Battery Volt Detect Fail	Battery voltage is abnormal. Please check if batteries are normal. Please check if battery fuses are broken on input power board.
65	Output Volt Fail	Output voltage is abnormal.
66	Bypass Volt Detect Fail	Bypass voltage is abnormal. Please check if bypass breaker is closed and is good. Please check if bypass cables are connected correctly.
67	INV Bridge Fail	Inverter IGBTs are broken and opened.
68	Outlet Temp Error	Outlet temperature of power module is over the limitation. Please check if fans are abnormal. Please check if PFC or inverter inductors are abnormal. Please check if air passage is blocked. Please check if ambient temperature is too high.
69	Input Curr Unbalance	The difference of input current between every two phases is over 40% of rated current. Please check if rectifier's fuses, diode, IGBT or PFC diodes are broken. Please check if input voltage is abnormal.
70	DC Bus Over Volt	Voltage of DC bus capacitors is over limitation. UPS shutdown rectifier and inverter.
71	REC Soft Start Fail	While soft start procedures are finished, DC bus voltage is lower than the limitation of calculation according utility voltage. Please check <ol style="list-style-type: none"> <li>1. Whether rectifier diodes are broken</li> <li>2. Whether PFC IGBTs are broken</li> <li>3. Whether PFC diodes are broken</li> <li>4. Whether drivers of SCR or IGBT are abnormal</li> <li>5. Whether soft start resistors or relay are abnormal</li> </ol>
72	Relay Connect Fail	Inverter relays are opened and cannot work or fuses are broken.
73	Relay Short Circuit	Inverter relays are shorted and cannot be released.
74	PWM Sync Fail	PWM synchronizing signal is abnormal
75	Intelligent Sleep	UPS works in intelligent sleep mode. In this mode, the power

		modules will be standby in turn. It will be more reliability and higher efficiency. It must be confirmed that remained power modules' capacity is big enough to feed load. It must be conformed that working modules' capacity is big enough if user add more load to UPS. It's recommended that sleeping power modules are waken up if the capacity of new added loads is not sure.
76	Manual Transfer to INV	Manually transfer UPS to inverter. It's used to transfer UPS to inverter when bypass is over track. The interrupt time could be over 20ms.
77	Input Over Curr Tout	Input over current timeout and UPS transfer to battery mode. Please check if input voltage is too low and output load is big. Please regulate input voltage to be higher if it's possible or disconnect some loads.
78	No Inlet Temp. Sensor	Inlet temperature sensor is not connected correctly.
79	No Outlet Temp. Sensor	Outlet temperature sensor is not connected correctly.
80	Inlet Over Temp.	Inlet air is over temperature. Make sure that the operation temperature of UPS is between 0-40°C.
81	Capacitor Time Reset	Reset timing of DC bus capacitors.
82	Fan Time Reset	Reset timing of fans.
83	Battery History Reset	Reset battery history data.
84	Byp Fan Time Reset	Reset timing of bypass fans.
85	Battery Over Temp.	Battery is over temperature. It's optional.
86	Bypass Fan Expired	Working life of bypass fans is expired, and it's recommended that the fans are replaced with new fans. It must be activated via software.
87	Capacitor Expired	Working life of capacitors is expired, and it's recommended that the capacitors are replaced with new capacitors. It must be activated via software.
88	Fan Expired	Working life of power modules' fans is expired, and it's recommended that the fans are replaced with new fans. It must be activated via software.
89	INV IGBT Driver Block	Inverter IGBTs are shutdown. Please check if power modules are inserted in cabinet correctly. Please check if fuses between rectifier and inverter are broken.
90	Battery Expired	Working life of batteries is expired, and it's recommended that the batteries are replaced with new batteries. It must be activated via software.
91	Bypass CAN Fail	The CAN bus between bypass module and cabinet is abnormal.
92	Dust Filter Expired	Dust filter need to be clear or replaced with a new one

102	Wave Trigger	Waveform has been saved while UPS fail
103	Bypass CAN Fail	Bypass and cabinet communicate with each other via CAN bus. Check If connector or signal cable is abnormal. If monitoring board is abnormal.
105	Firmware Error	Manufacturer used only.
106	System Setting Error	Manufacturer used only.
107	Bypass Over Temp.	Bypass module is over temperature. Please check If bypass load is overload If ambient temperature is over 40°C If bypass SCRs are assembled correctly If bypass fans are normal
108	Module ID Duplicate	At least two modules are set as same ID on the power connector board, please set the ID as correct sequence

#### Note

Different colors of the words represent different level of events:

- (a) Green, an event occurs;
- (b) Grey, the event occurs then clears;
- (c) Yellow, warning occurs;
- (d) Red, faults happen.

### 3.2.5 Operate

Touch the icon  (At the bottom of the screen), and the system enters the page of the “Operate”, as it is shown in Figure3-10.

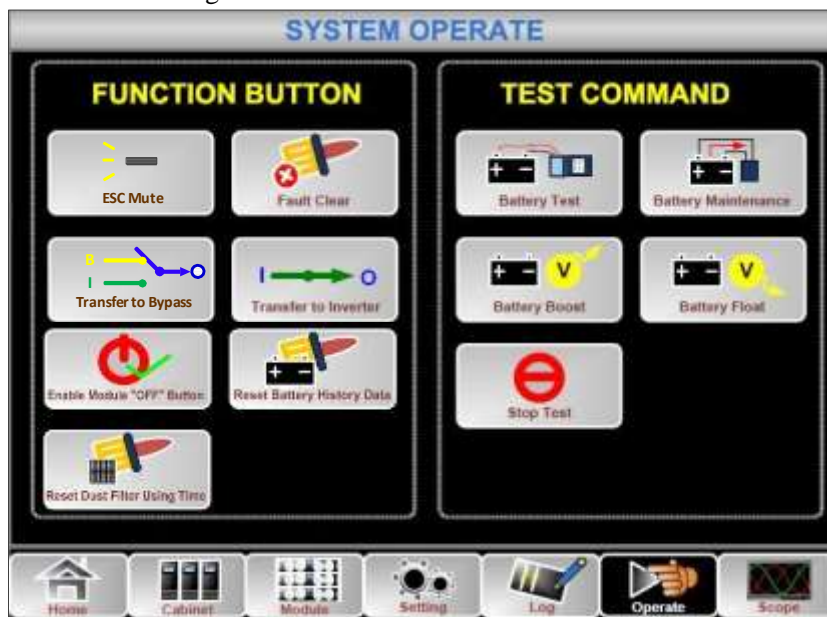



Figure3-10 Operate menu

The “Operate” menu includes FUNCTIONBUTTON and TESTCOMMAND. The contents are described in details below.

**FUNCTION BUTTON**



**Clear/Restore Buzzer**

Mute or Restore buzzing of the system by touching the icon  or .

**Fault Clear**

Clear the faults by touching the icon .

**Transfer to and ESC Bypass**

Transfer to bypass mode or cancel this command by touching the icon  or .

**Transfer to Inverter**

Transfer the bypass mode to Inverter Mode by touching the icon .

**Enable Module “OFF” Button**

Enable the switch for powering off the Power Module by touching the icon .

**Reset Battery History Data**

Reset the battery history data by touching the icon , the history data includes the times of discharge, days for running and hours of discharging.

**Reset Dust filter Using Time**

Reset the time of dust filter using by touching the icon , it includes the days of using and maintenance period.

**TEST COMMAND**

**Battery Test**

By touching the icon , the system transfer to the Battery mode to test the condition of the battery. Ensure the bypass is working normally and the capacity of the battery is no less than 25%.

**Battery Maintenance**

By touching the icon , the system transfers to the Battery mode. Thisfunction is used for maintaining the battery, which requires the normalityof the bypass and minimum capacity of 25% for the battery.

**Battery Boost**

By touching the icon , the system starts boost charging.

**Battery Float**

By touching the icon , the system starts float charging.

**Stop Test**

By touching the icon , the system stops battery test or battery maintenance.

### 3.2.6 Scope

Touch the icon  (At the bottom right of the screen), and the system enters the page of the Scope, as it is shown in Figure3-11.

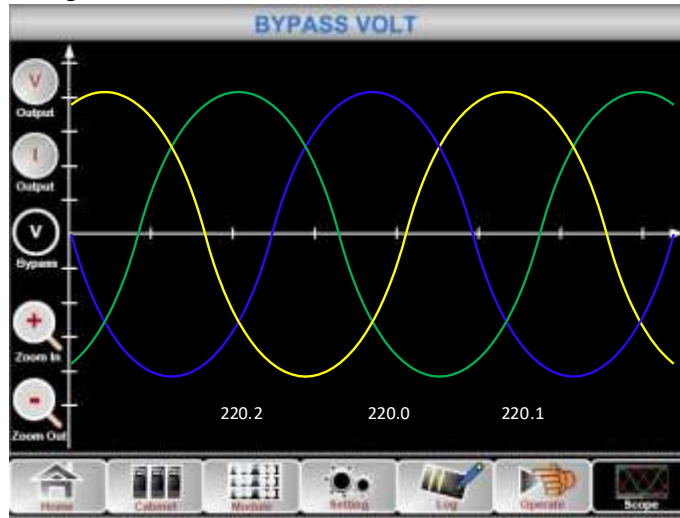

Figure3-11 Scope Menu

Users can view the waves for output voltage, output current and bypass voltage by touching the corresponding icon in the left side of the interface. The waves can be zoomed in and zoom out.



Touch the icon to display the 3 phase output voltage.



Touch the icon to display the 3 phase output current.



Touch the icon to display the 3 phase bypass voltage.



Touch the icon to zoom in the wave.



Touch the icon to zoom out wave.

## 4 Operations

### 4.1 UPS Start-up

#### 4.1.1 Start in Normal Mode

The UPS must be started up by commissioning engineer after the completeness of installation. The steps below must be followed:

- 1) Ensure all the circuit breakers are open.
- 2) One by one to turn on the output breaker (Q4), input breaker (Q1), bypass input breaker (Q2), and then the system starts initializing (150kVA - 300kVA only have a manual bypass breaker, so need to used external circuit breakers).
- 3) The LCD in front of the cabinet is lit up. The system enters the home page, as shown in Figure3-2.
- 4) Notice the energy bar in the home page, and pay attention to the LED indicators. The rectifier flashes indicating the rectifier is starting up. The LED indicators are listed below in Table 4-1.

Table 4-1 Rectifier starting up

Indicator	Status	Indicator	Status
Rectifier	green flashing	Inverter	off
Battery	red	Load	off
Bypass	off	Status	red

- 5) After 30S, the rectifier indicator goes steady green, presenting the finishing of rectification and bypass static switch closes then the inverter is starting up. The LED indicators are listed below in Table 4-2.

Table 4-2 Inverter starting up

Indicator	Status	Indicator	Status
Rectifier	green	Inverter	green flashing
Battery	red	Load	green
Bypass	green	Status	red

- 6) The UPS transfers from the bypass to inverter after the inverter goes normal. The LED indicators are listed below in Table 4-3.

Table 4-3 Supplying the load

Indicator	Status	Indicator	Status
Rectifier	green	Inverter	green
Battery	red	Load	green
Bypass	off	Status	red

- 7) The UPS is in Normal Mode. Close the battery circuit breakers and the UPS starts charging the battery. The LED indicators are listed below in Table 4-4.

Table 4-4 Normal mode

Indicator	Status	Indicator	Status
Rectifier	green	Inverter	green
Battery	green	Load	green
Bypass	off	Status	green

### Note

When the system starts, the stored setting will be loaded.

Users can browse all events during the process of the starting up by checking the menu Log.

Users can check the information of the power unit by the keys in the front of it.

## 4.1.2 Start from Battery

The start from battery is referring to battery cold start. The steps for the start-up are as follows:

- 1) Confirm the battery is correctly connected; turn on the external battery circuit breakers.
- 2) Press the red button for the battery cold start (as shown in Figure4-1).The system is then powered by the battery.

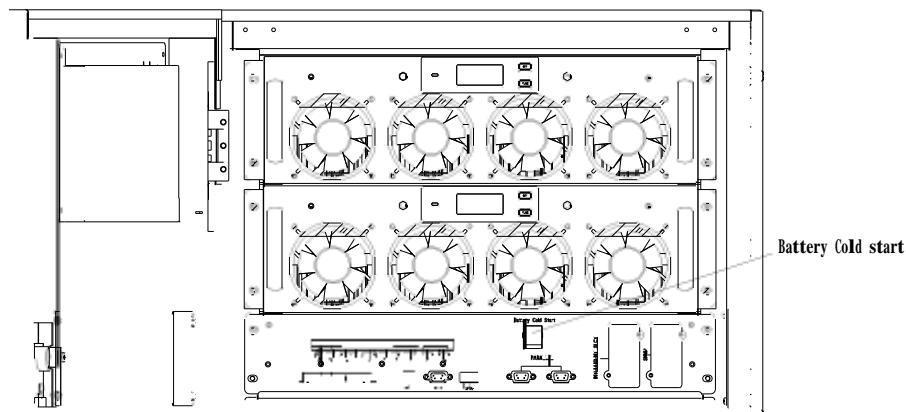

Figure4-1 The position of the battery cold start button

- 3) After that, the system is starting up following steps 3 in chapter 4.1.1 and the system transfers to battery mode in 30S.
- 4) Turn on the external output power supply isolation to supply the load, and the system is working on battery model.

### Note

The battery cold start function is optional in 60kVA-200kVA, standard in 250kVA - 500kVA.

## 4.2 Procedure for Switching between Operation Modes

### 4.2.1 Switching the UPS into Battery Mode from Normal Mode

The UPS transfers to Battery model immediately after the utility (mains voltage) is failed or drops down below the predefined limit.

### 4.2.2 Switching the UPS from Normal Mode into Bypass Mode

- 1) Enter the menu Operate, touch the icon “transfer to bypass”  and the system transfers to bypass mode ;
- 2) Press and hold the BYP key on the operator control panel for longer than two seconds and the system transfers to bypass mode. This needs to enable the switch behind the front door. As shown in Figure4-2.

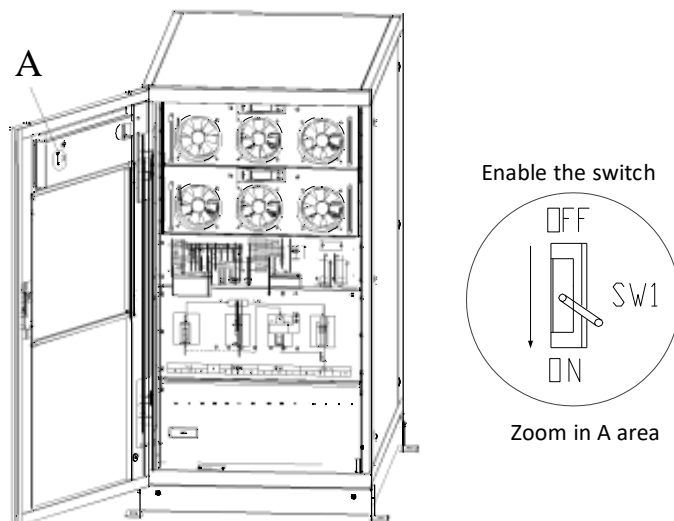



Figure4-2 Enable the switch

**Warning**

Ensure the bypass is working normally before transferring to bypass mode. Or it may cause failure.

**4.2.3 Switching the UPS into Normal Mode from Bypass Mode**

Two ways to transfer the UPS into Normal mode from Bypass Mode:

- (a) Enter the menu Operate, touch the icon transfer to inverter  and the system transfers to bypass mode.
- (b) Press and hold the **INV** key on the operator control panel for longer than two seconds and the system transfers to Normal mode.

**Note**

Normally, the system will transfer to the Normal mode automatically. This function is used when the frequency of the bypass is over track and when the system needs to transfer to Normal mode by manual.

**4.2.4 Switching the UPS from Normal Mode into Maintenance Bypass Mode**

These following procedures can transfer the load from the UPS inverter output to the maintenance bypass supply, which is used for maintaining.

- 1) Transfer the UPS into Bypass mode following section 5.2.2.
- 2) The inverter indicator LED goes out, status indicator LED goes out, the buzzer alarm, the inverter shutdown. The bypass supplies power to loads.
- 3) Turn off the external battery breaker and turn on the maintenance bypass breaker. And the load is powered through maintenance bypass and static bypass.
- 4) One by one to turn off the input breaker (Q1), bypass input breaker (Q2), output breaker (Q4), and then the system shutdown (150kVA - 300kVA only have a manual bypass breaker, so need to used external circuit breakers). The maintenance bypass supplies power to loads.

 **Note**

150kVA - 300kVA only have a manual bypass breaker. In manual bypass mode (The manual bypass supplies power to loads), dangerous voltages are present on terminal and internal Copper bar.

150kVA -300kVA need to use external circuit breakers (Includes external input breaker, external bypass input breaker, external output breaker and external maintenance bypass breaker).

**Warning**

Before making this operation, read messages on LCD display to be sure that bypass supply is regular and the inverter is synchronous with it, so as not to risk a short interruption in powering the load.

**Danger**

If you need to maintain the power unit, wait for 10 minutes to let the DC bus capacitor fully discharge before removing the cover.

#### 4.2.5 Switching the UPS into Normal Mode from Maintenance Bypass Mode

These following procedures can transfer the load from the Maintenance Bypass to inverter output.



- 1) One by one to turn on the output breaker (Q4), input breaker (Q1), bypass input breaker (Q2), and then the system starts initializing.
- 2) After 30S, the static bypass turns on, the bypass indicator LED goes green, and the load is powered through maintenance bypass and static bypass.
- 3) Turn on the external battery breaker.
- 4) Turn off the maintenance bypass breaker and the load is powered through static bypass.
- 5) After 30S, the rectifier starts, the rectifier indicator LED goes green, and then inverter starts.
- 6) After 60S, the system transfers to Normal mode.

 **Note**

150KVA - 300KVA operation, please refer to chapter 5.3.2.

### 4.3 Battery Manual

If the battery is not in use for a long time, it is necessary to test the condition of the battery. Two methods are provided:

- 1) Manual Discharging test. Enter the menu Operate, as is shown in Figure4-3 and touch the icon “Battery maintenance”  , the system transfers into the Battery mode for discharging. The system will stop discharging when the battery will have 20% of capacity or in low voltage. Users can stop the discharging by touching the “Stop Test” icon .

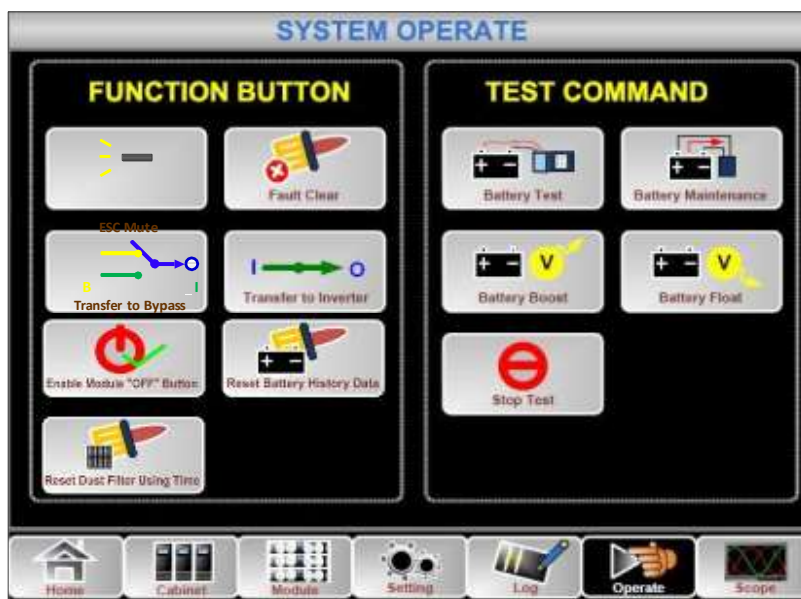

Figure4-3 Battery maintenance

- 2) Auto discharging. The system can maintain the battery automatically when the setting is done. The setting procedures are as follows.
  - (a) Enable battery auto discharge. Enter the "CONFIGURE" page of the menu Setting, tick the "Battery Auto Discharge" and confirm (This needs to be done by factory).
  - (b) Setting period for battery auto discharge. Enter the "BATTERY" page of the Setting (See Figure4-4), Set the period time in the item "Auto Maintenance Discharge Period" and confirm.



Figure4-4 Setting period for battery auto discharge



**Warning**

The load for the auto maintenance discharge should be 20%-100%, if not, the system will not start the process automatically.

## 4.4 EPO

The EPO button located in the operator control and display panel (with cover to avoid disoperation, see Figure4-5) is designed to switch off the UPS in emergency conditions (e.g., fire, flood, etc.). To achieve this, just press the **EPO** button, and the system will turn off the rectifier, inverter and stop powering the load immediately (including the inverter and bypass), and the battery stops charging or discharging.

If the input utility is present, the UPS control circuit will remain active; however, the output will be turned off. To completely isolate the UPS, users need to turn off the external mains input supply to the UPS. Users can restart the UPS by powering the UPS again.



### Warning

When the EPO is triggered, the load is not powered by the UPS. Be careful to use the EPO function.

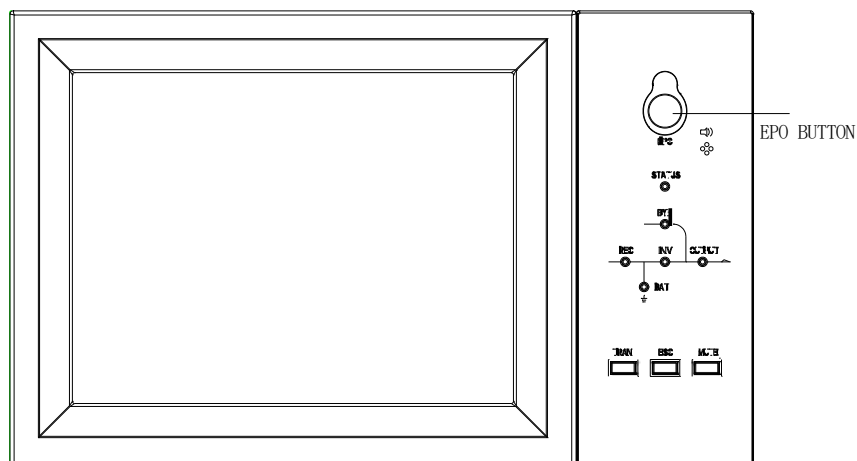

Figure4-5 EPO Button

### 4.5 Installation of Parallel Operation System

The UPS system can have three cabinets in parallel.  
Two UPS cabinets are connected as is shown in Figure4-6.

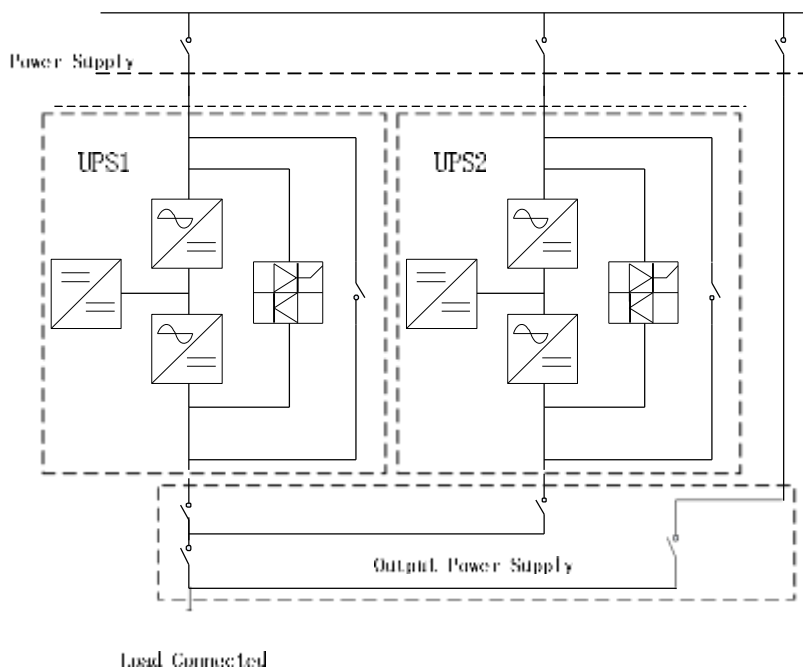
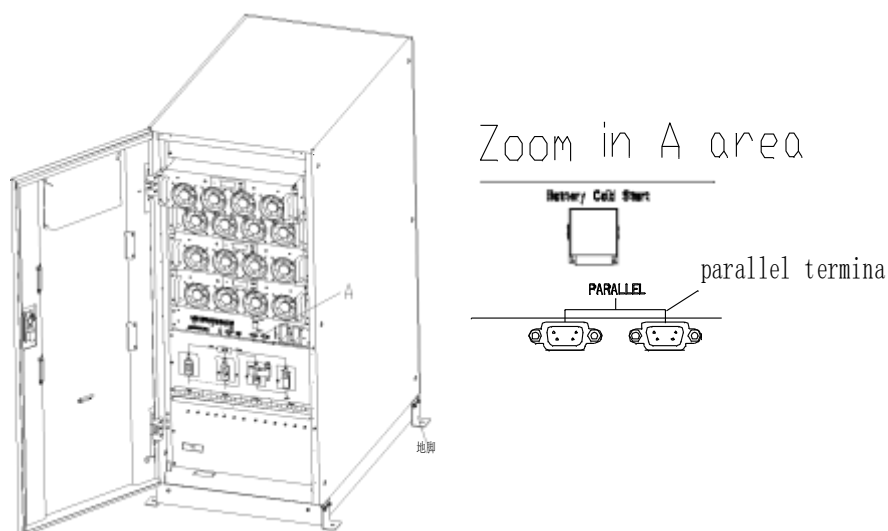
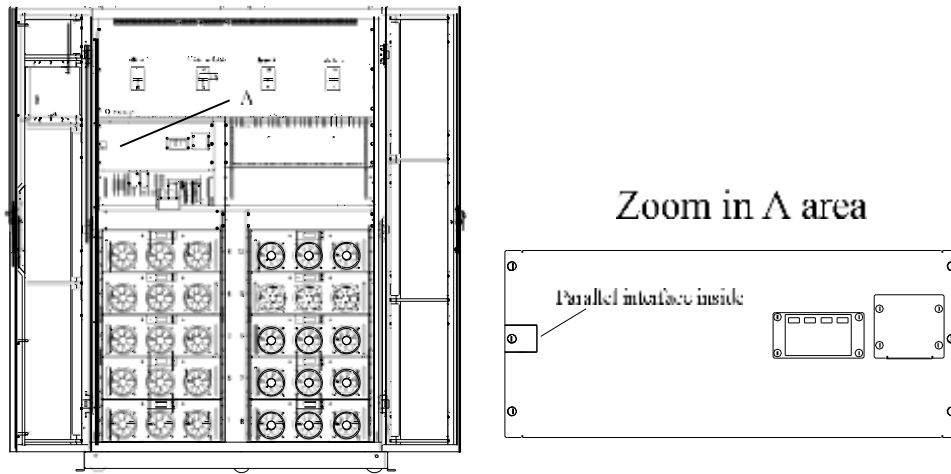

Figure4-6 Parallel diagram

The parallel interfaces of 60kVA-300kVA are located in the front panel of the cabinet, and the 400kVA -500kVA are located inside the cabinet, open the panel can see. The parallel terminal is shown in Figure4-7.



(a) The parallel interfaces of 60kVA-300kVA



(b) The parallel interfaces of 4000kVA and 500kVA

Figure4-7 Location of the Parallel interface

The control cables for the parallel operation must be connected with all single devices to form a closed loop, as is shown in Figure4-8.

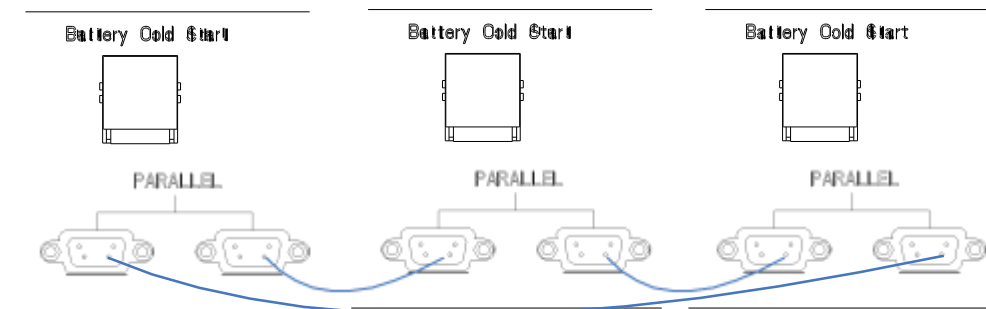

Figure4-8 Parallel connection

For more details of parallel operation, please refer to the “Instruction for Parallel Operation of Tower UPS”.

## 5 Maintenance

This chapter introduces UPS maintenance, including the maintenance instructions of power unit, monitor unit and bypass unit and the replacement method of dust filter.



### 5.1 Precautions

Only maintaining engineers can maintain the power unit, monitor unit and bypass unit.

- 1) The power unit should be disassembled from top to bottom, so as to prevent any inclination from high gravity center of the cabinet.
- 2) To ensure the safety before maintaining power unit and monitor unit, use a multimeter to measure the voltage between operating parts and the earth to ensure the voltage is lower than hazardous voltage, i.e. DC voltage is lower than 36Vdc, and AC maximum voltage is lower than 30Vac.
- 3) Monitor unit and bypass unit is not recommended to hot swap; only when UPS is in Maintenance Bypass Mode or UPS is completely powered off, the monitor unit and bypass unit can be disassembled.
- 4) Wait 10 minutes before opening the cover of the power unit after pulling out from the Cabinet.

### 5.2 Instruction for Maintaining Power unit

Confirm the UPS is operating in Normal Mode and the bypass is working normally before pulling out the power unit needed to be repaired.

- 1) Ensure the remaining power module will not be overloaded.
- 2) Power off the power unit:
  - a) Enable. LCD panel->Menu Operate ->Enable Module "OFF" icon .
  - b) Press the "OFF" button on the power unit panel for 3 seconds, the power unit quits from the system.
- 3) Remove the mounting screw on the two front sides of the power unit and pull out the power unit by two persons.
- 4) Wait 10minutes before opening the cover for repairing.
- 5) After the repairing is done, push the power unit into the cabinet and the power unit will automatically join the system.

### 5.3 Instruction for Maintaining monitor unit and bypass unit

#### 5.3.1 Maintaining monitor unit and bypass unit for 60kVA-120kVA

Confirm the UPS is operating in Normal mode and the bypass is working normally

- 1) Transfer the system to bypass mode through the LCD control panel (Refer to chapter 4.2.2).
- 2) Turn on the maintenance bypass breaker. The load is powered through maintenance bypass and static bypass.
- 3) One by one to turn off the battery breaker, input breaker, bypass input breaker and output breaker. The load is powered through maintenance bypass.
- 4) Take out two power units, which are close to the monitoring unit and the bypass unit, can be taken to repair the monitoring and the bypass unit.
- 5) After the completion of maintenance, insert power unit and tighten the screws on both sides of the power unit.
- 6) One by one to turn on the output breaker, bypass input breaker, input breaker and battery breaker.
- 7) After 2 minutes, the bypass indicator LED goes green, and the load is powered through

- maintenance bypass and static bypass.
- 8) Turn off the maintenance bypass breaker.
  - 9) After 30S, the rectifier starts, the rectifier indicator LED goes green, and then inverter starts.
  - 10) After 60S, the system transfers to Normal mode.

### 5.3.2 Maintaining monitor unit and bypass unit for 150kVA and 300kVA

Confirm the UPS is operating in Normal mode and the bypass is working normally

- 1) Transfer the system to bypass mode through the LCD control panel (Refer to chapter 4.2.2).
- 2) Turn on the manual bypass breaker.
- 3) Turn on the external maintenance bypass breaker.
- 4) One by one to turn off the battery breaker, external input breaker, external bypass input breaker, and external output breaker. The load is powered through external maintenance bypass.
- 5) Take out two power units, which are close to the monitoring unit and the bypass unit, can be taken to repair the monitoring and the bypass unit;
- 6) After the completion of maintenance, insert power unit and tighten the screws on both sides of the power unit.
- 7) One by one to turn on the external output breaker, external bypass input breaker, external input breaker and battery breaker.
- 8) After 2 minutes, the bypass indicator LED goes green, and the load is powered through external maintenance bypass, manual bypass and static bypass.
- 9) Turn off the external maintenance bypass breaker. The load is powered through manual bypass and static bypass.
- 10) Turn off the manual bypass breaker.
- 11) After 30S, the rectifier starts, the rectifier indicator LED goes green, and then inverter starts.
- 12) After 60S, the system transfers to Normal mode.

### 5.3.3 Maintaining monitor unit and bypass unit for 400kVA and 500kVA

Confirm the UPS is operating in Normal mode and the bypass is working normally

- 1) Transfer the system to bypass mode through the LCD control panel (Refer to chapter 4.2.2).
- 2) Turn on the maintenance bypass breaker. The load is powered through maintenance bypass and static bypass.
- 3) One by one to turn off the battery breaker, input breaker, bypass input breaker and output breaker. The load is powered through maintenance bypass.
- 4) Take out the panel above the monitoring unit, and can repair the monitoring unit
- 5) Take out the panel at the top of the bypass unit and the right side door panel of the cabinet, and repair the bypass unit.
- 6) After the completion of maintenance, install panel and tighten the screws.
- 7) One by one to turn on the output breaker, bypass input breaker, input breaker and battery breaker.
- 8) After 2 minutes, the bypass indicator LED goes green, and the load is powered through maintenance bypass and static bypass.
- 9) Turn off the maintenance bypass breaker.
- 10) After 30S, the rectifier starts, the rectifier indicator LED goes green, and then inverter starts.
- 11) After 60S, the system transfers to Normal mode.

## 5.4 Battery Setting

The setting of battery needs to be done after the first time of powering off or any changes done on the batteries.

The battery configuration can be done through the LCD control panel (Figure5-1) or through monitoring software (Figure5-2).



Figure5-1 Configuration through LCD control panel

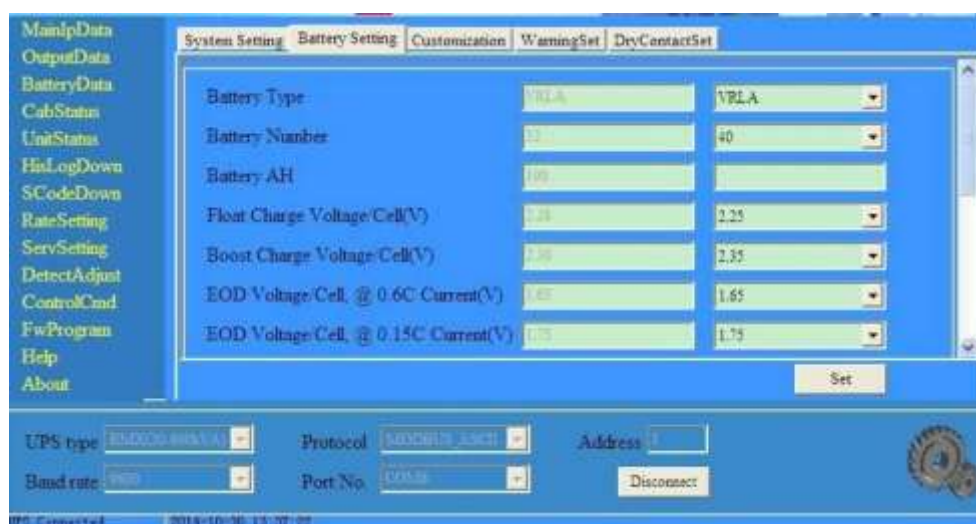

Figure5-2 Configuration through monitoring software

#### 5.4.1 Setting of Battery Type

The battery type can be only set through the monitoring software. The system at present supports lead acid battery and Lithium iron phosphate battery (LFPB).

#### 5.4.2 Setting of Battery Number

##### 1) Setting battery number for Lead- Acid battery

The nominal voltage of one block battery is 12V and for each block of battery, it consists of 6 cells (each cell of 2V). For the setting, as is shown in Figure5-1, if the battery is 40, it means that there are 40 blocks of batteries and both the positive and negative are 20 blocks of batteries. In the case of cell battery of 2V (usually with large capacity) is used, battery number should be the same as the block battery. The cell battery actually in use should be 240 cells (6\*40), with both and positive and negative of 120 cells. The battery number setting range is 36-44

##### 2) Setting battery number for LFPB

For the cell of each LFPB, the cell voltage is 3.2V; each battery block consists of 1 cell. In total, if 40 blocks of Lead- Acid battery are used, for the LFPB, the number will be 150. Both the positive and negative are 75 cells.

The battery number setting range is 140-180. The lowest EOD voltage for the LFPB will be 360V and highest voltage can be 620V.

### 5.4.3 Battery Capacity Setting

Battery Capacity Setting sets the capacity value of the battery block. For example, if the system uses 40 blocks of 12V/100AH batteries, the Battery Capacity Setting should be set to 100 Ah. If 240 cells of 2V/1000AH are used, the Battery Capacity Setting should be set to 1000 Ah.

In case of there are more than one strings of battery in parallel, the battery capacity setting value will be the times of the single string. For instance, if the configuration is two strings of 40 blocks of 12V/100AH batteries, the battery capacity setting should be set to 200AH.

The system sets current limits according to the battery capacity set. For the Lead-Acid battery, the current limit is 0.2C, and for the LFPB, the current is 0.3C. For instance, the 500kVA is configured to 40 blocks of 12V/500AH batteries, which can provide total max charging current of 160A. Due to the current limits (0.2C), the max charging current will be 100A (0.2\*500A).

### 5.4.4 Float and Boost Charge Setting

In boost charging, the system charges the batteries with constant current. After the period, the system will enter the float charging.

For the Lead-Acid battery, the default float charge voltage per cell is 2.25V, boost charge voltage is 2.35V;

For the LFPB, the default float and boost charge voltage per cell is 3.45V

### 5.4.5 EOD Voltage Setting

The EOD voltage 0.6C is the EOD voltage when the discharging current is larger than 0.6C; EOD voltage 0.15C is the EOD voltage when the discharging current is less than 0.15C. EOD voltage decreases linearly as the EOD voltage Current increases from 0.15C and 0.6C, as shown in Figure 5-3.

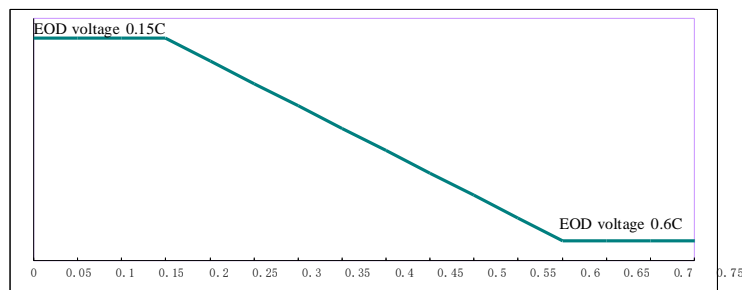

Figure 5-3 EOD voltage

For Lead-Acid battery, the cell voltage is suggested to be set to 1.65V/cell at 0.6C, and set to 1.75V at 0.15C

For the LFPB battery, the cell voltage is suggested to be set to 2.7V/cell at both 0.6C and 0.15C.

### 5.4.6 Charging Current Percent Limit

This setting is for limiting the charging power, max current limit can be 20% of the rated active power. The max current that one power unit can give according to the current limit (in percentage) is shown in Table 5-1.

The actual charging current is also limited to the battery capacity. Refer to chapter 5.4.3.

Table 5-1 Current limit for per power unit

Current limit (%)	Max charging current(A)	
	30KVA power unit	50KVA power unit
1	0.5	0.8
2	0.9	1.6
3	1.4	2.4
4	1.9	3.2
5	2.3	4.0
6	2.8	4.8
7	3.3	5.6
8	3.8	6.4
9	4.2	7.2
10	4.7	8.0
11	5.2	8.8
12	5.6	9.6
13	6.1	10.4
14	6.6	11.2
15	7.0	12.0
16	7.5	12.8
17	8.0	13.6
18	8.4	14.4
19	8.9	15.2
20	9.4	16.0

#### 5.4.7 Battery Temperature Compensate

This is for setting the temperature compensate coefficient. Based on 25°C , when the temperature is higher than that, the discharging voltage goes lower; When the temperature is lower than that, the discharging voltage goes higher.

#### 5.4.8 Boost Charge Time Limit

This is for setting the Boost Charge time. The system transfers to float charge when the boost Charge time has passed. The setting range can be 1-48h.

#### 5.4.9 Auto Boost Period

This is for setting the Auto boost period time. The system boost charges the battery when the reaching the Auto boost period. It is suggested to boost charge the battery every three month, set the period to 4320h.

#### 5.4.10 Auto maintenance Discharge Period

The system discharges the battery when the reaching the Auto maintenance discharge period. This function should be enabled by checking the AutoMaint (Rate Setting->SysCodeSetting1) through the monitoring software, as shown in Figure5-4.

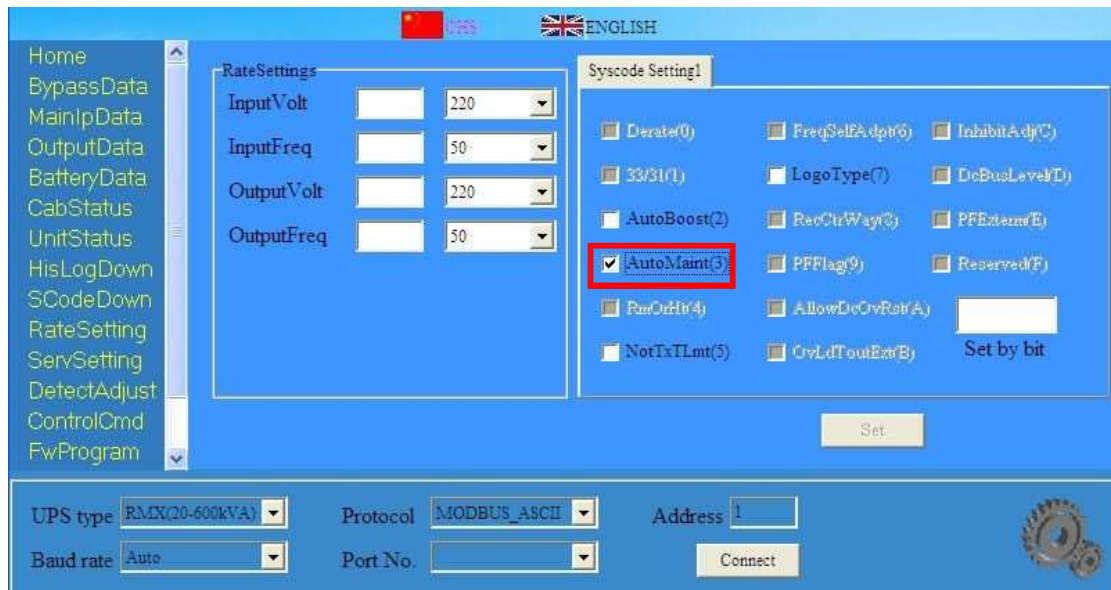

Figure5-4 Enable the Auto maintenance Discharge period

The EOD voltage of Auto maintenance Discharge is 1.05 times of the normal EOD voltage.

#### 5.4.11 Warnings for Battery and Environment Temperature Overheat

This function can be set through the monitoring software. The system will read the temperature information of the battery and environment and give warning of overheat.

The set range is 25-70 °C.

The temperature sensor should be placed through the Dry Contact.

## 5.5 Replacing Dust Filter (optional)

There are 3~4 dust filters on the back of UPS' front door, each filter is held in place by a bracket on either side of each filter. The procedure of replacing each filter is as follows:

1. Open the front door and locate the filters on the back side of the front door.
2. Remove one bracket.
3. Remove the dust filter to be replaced and insert the clean one.
4. Reinstall the bracket.

## 6 Product Specification

This chapter provides the specifications of the product, including environmental characteristics, mechanical characteristics and electrical characteristics.

### 6.1 Applicable Standards

The UPS has been designed to conform to the following European and international standards:

Table 6-1 Compliance with European and International Standards

Item	Normative reference
General safety requirements for UPS used in operator access areas	EN50091-1-1/IEC62040-1-1/AS 62040-1-1
Electromagnetic compatibility (EMC) requirements for UPS	EN50091-2/IEC62040-2/AS 62040-2 (C3)
Method of specifying the performance and test requirements of UPS	EN50091-3/IEC62040-3/AS 62040-3 (VFI SS 111)

#### Note

The above mentioned product standards incorporate relevant compliance clauses with generic IEC and EN standards for safety (IEC/EN/AS60950), electromagnetic emission and immunity (IEC/EN/ AS61000 series) and construction (IEC/EN/AS60146 series and 60950).

### 6.2 Environmental Characteristics

Table 6-2 Environmental Characteristics

Item	Unit	Requirements
Acoustic noise level at 1 meter	dB	65dB @ 100% load, 62dB @ 45% load
Altitude of Operation	m	≤1000, load derated 1% per 100m from 1000m and 2000m
Relative Humidity	%RH	0-95, non-condensing
Operating Temperature	°C	0-40, Battery life is halved for every 10°C increase above 20°C
UPS Storage Temperature	°C	-40-70
Recommended battery storage temperature	°C	-20~30

## 6.3 Mechanical Characteristic

Table 6-3 Mechanical Characteristics for Cabinet

Model	Unit	60kVA	80kVA	90kVA	100kVA	120kVA
Mechanical Dimension (W*D*H)	mm	600*980*950	600*980*1150	600*980*1400	600*980*1150	600*980*1400
Weight	kg	170	210	231	210	266
color	N/A	Black				
Protection Level, (IEC60529)	N/A	IP20				
Model	Unit	150kVA	200kVA	250kVA	300kVA	
Mechanical Dimension (W*D*H)	mm	650*960*1600	650*960*1600	650*970*2000	650*1095*2000	
Weight	kg	305	350	445	490	
color	N/A	Black				
Protection Level, (IEC60529)	N/A	IP20				
Model	Unit	400kVA		500kVA		
Mechanical Dimension (W*D*H)	mm	1300*1100*2000		1300*1100*2000		
Weight	kg	810		900		
color	N/A	Black				
Protection Level, (IEC60529)	N/A	IP20				

Table 6-4 Mechanical Characteristics for power unit

Model	Unit	30kVApowerunit	50kVApowerunit
Mechanical Dimension (W*D*H)	mm	460×790×134	510*700*178
Weight	kg	34	45

## 6.4 Electrical Characteristics

### 6.4.1 Electrical Characteristics (Input Rectifier)

Table 6-5 Rectifier AC input (Mains)

Item	Unit	Parameter
Grid System	\	3 Phases + Neutral + Ground
RatedACInputVoltage	Vac	380/400/415(three-phase and sharing neutral with the bypass input)
Rated Frequency	Vac	50/60Hz
Inputvoltagegerange	Vac	304~478Vac (Line-Line),full load 228V~304Vac (Line-Line),load decrease linearly according to the min phase voltage
Input Frequency range	Hz	40~70
Input Power factor	PF	>0.99
THDI	THDI%	<3% (full Linear Load)

### 6.4.2 Electrical Characteristics (Intermediate DC Link)

Table 6-6 Battery

Items	Unit	Parameters
Battery bus voltage	Vdc	Rated: $\pm 240V$
Quantity of lead-acid cells	Nominal	40=[1 battery(12V)] ,240=[1 battery(2V)]
Floatchargevoltage	V/cell (VRLA)	2.25V/cell(selectable from 2.2V/cell~2.35V/cell) Constant current and constant voltage charge mode
Temperature compensation	mV/°C/cl	3.0(selectable:0~5.0)
Ripplevoltage	%	$\leq 1$
Ripple current	%	$\leq 5$
Equalized charge voltage	VRLA	2.4V/cell(selectable from : 2.30V/cell~2.45V/cell) Constant current and constant voltage charge mode
Final discharging voltage	V/cell (VRLA)	1.65V/cell(selectable from: 1.60V/cell~1.750V/cell) @0.6C discharge current 1.75V/cell (selectable from: 1.65V/cell~1.8V/cell) @0.15C discharge current (EOD voltage changes linearly within the set range according to discharge current)
BatteryCharge	V/cell	2.4V/cell(selectable from : 2.3V/cell~2.45V/cell) Constant current and constant voltage charge mode
Battery Charging Power Max Current	kW	10% * UPS capacity (selectable from : 1~20% * UPS capacity)

### 6.4.3 Electrical Characteristics (Inverter Output)

Table 6-7 Inverter Output (To critical load)

Item	Unit	Value
Rated capacity	KVA	80/100/120
Rated AC voltage	Vac	380/400/415 (Line-Line)
Rated Frequency	Hz	50/60
Frequency Regulation	Hz	50/60Hz $\pm 0.1\%$
Static Voltage regulation	%	$\pm 1$ (0~100% linear load)
Overload	\	110%, 60min; 125%, 10min; 150%, 1min; >150%, 200ms
Synchronized Range	Hz	Settable, $\pm 0.5Hz \sim \pm 5Hz$ , default $\pm 3Hz$
Synchronized Slew Rate	Hz	Settable, 0.5Hz/S $\sim$ 3Hz/S, default 0.5Hz/S
Output Power Factor	PF	0.9
Transient Response	%	<5% for step load (20% - 80% -20%)
Transient recovery		< 30ms for step load (0% - 100% -0%)
Output Voltage THDu		<1% from 0% to 100% linear load <6% full non-linear load according to IEC/EN62040-3

## 6.4.4 Electrical Characteristics (Bypass Mains Input)

Table 6-8 Bypass Mains Input

Item	Unit	60kVA-200kVA	250kVA-500kVA
RatedACvoltage	Vac	380/400/415 (three-phase four-wire and sharing neutral with the bypass)	
Rated Current	A	91~758(Table3-2)	
Overload	%	125%, Long term operation 125%~130%, for 10 min 130%~150%, for 1min >150%,300ms	110%, Long term operation 110%~125%, for 5 min 125%~150%, for 1 min >150%,1S
Current rating of neutral cable	A	1.7×In	1.7×In
Rated frequency	Hz	50/60	50/60
Switch time (between bypass and inverter)	ms	Synchronized transfer: 0ms	
Bypassvoltage range	%	Settable, default -20%~+15% Up limited: +10%, +15%, +20%, +25% Down limited: -10%, -15%, -20%, -30%, -40%	
Bypass frequency range	Hz	Settable, ±1Hz, ±3Hz, ±5Hz	
Synchronized Range	Hz	Settable ±0.5Hz~±5Hz,default ±3Hz	

## 6.5 Efficiency

Table 6-9 Efficiency

Item	Unit	60kVA /90 kVA /120 kVA	80kVA/100 kVA /150 kVA - 500 kVA
Overall efficiency			
Normal mode(dual conversion)	%	>95	>96
ECO mode	%	>99	
Battery discharging efficiency (battery at nominal voltage 480Vdc and full-rated linear load)			
Battery mode	%	>95	>96

## 6.6 Display and Interface

Table 6-10 Display and Interface

Display	LED + LCD +Color touch screen
Interface	Standard:RS232, RS485, USB, Dry Contact Option: SNMP,AS/400

## Recycling information in accordance with the WEEE

The product is marked with the wheelie bin symbol. It indicates that at the end of life the product should enter the recycling system.

You should dispose of it separately at an appropriate collection point and not place it in the normal waste stream.

The figure below shows the wheelie bin symbol indicating separate collection for electrical and electronic equipment (EEE).

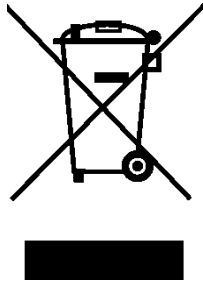

The Horizontal bar underneath the crossed-out wheelie bin indicates that the equipment has been manufactured after the Directive came into force in 2005.

The main parts of the drive can be recycled to preserve natural resources and energy. Product parts and materials should be dismantled and separated.

Contact your local distributor for further information on environmental aspects. End of life treatment must follow international and national regulations.

